

BRITISH MAIN BATTLE TANK

CHIEFTAIN MK.5/5P

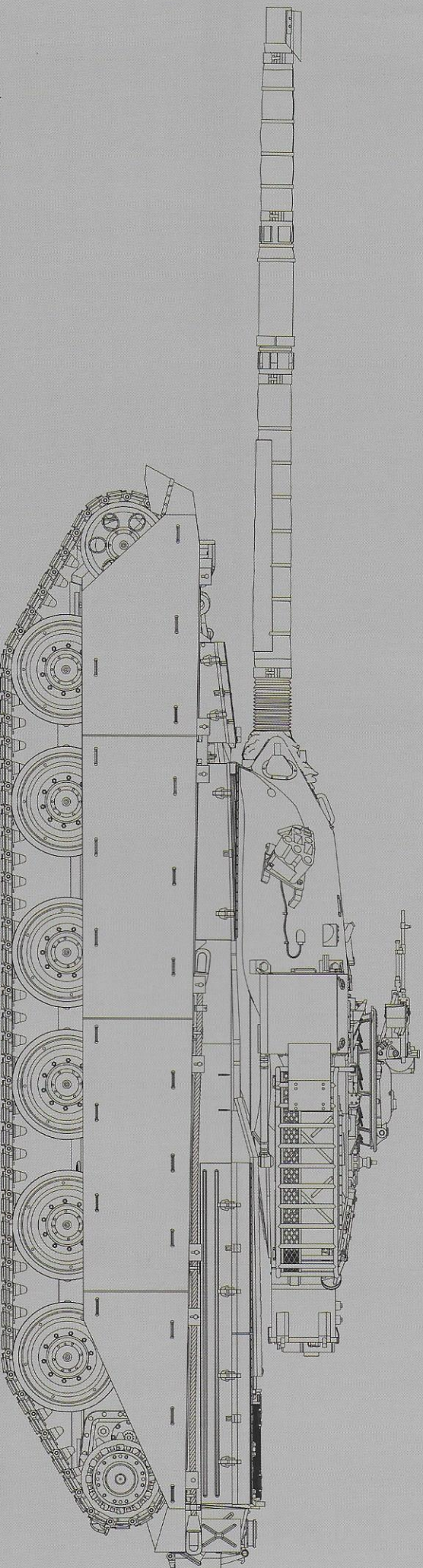

Development of what was to become the Chieftain began in 1946 as the "Universal tank" concept, development was long and convoluted with many dead ends and radical concepts investigated along the way but the final result was the first true Main Battle Tank (MBT).

The Chieftain was a basically conventional design with an engine to the rear, central fighting compartment and forward centrally located driver's position. The vehicle was manned by a 4 man crew, Driver, Gunner, Loader and Commander. Several radical features did however make it into the final design. These included a reclined driving position which allowed for a lower silhouette and more steeply sloped frontal armour, an unexpected benefit of which was to give the driver a very comfortable bed! The Rifled L11 120mm gun was designed to use separate propellant and projectiles with all the explosive materials stored in refrigerated charge bins below the level of the turret ring to improve survivability. Both the turret front and hull forward of the turret were huge one piece castings which for many years were proof against any Russian Tank or artillery rounds. The L60 multi fuel Engine was yet another radical feature but sadly this proved to be Achilles heel of the Chieftain and led to its deserved reputation for unreliability. With a decent Diesel engine the Chieftain would have been a world beater.

The Mk.5 was the definitive Chieftain and incorporated improvements from previous Marks and extensive overseas testing. These included an improved commanders cupola. Upgraded NBC pack, Fire control system, Commanders and Gunners sights, increased ammunition storage and a thermal sleeve for the main armament. A .50 calibre ranging gun was used in the initial Mk.5. This version was mass produced for the British Army and an additional 900+ Chieftains of this build standard were also exported to Iran as the Mk.5P. Later Mk.5's had the ranging gun removed and a Laser sight installed and designated Mk.5L. The Chieftain was for many years the most powerful Tank in NATO if not the world and was rightly feared by the Soviets/Russians. Just how effective the Mk.5 could be was shown when a reduced Squadron of Kuwaiti Mk.5K's engaged a Battalion of Iraqi T.72's in the first Gulf war and destroyed at least 53 without loss before the Iraqis fled the battlefield. The Kuwaiti tanks then withdrew safely over the Saudi Border due to a lack of ammunition.

03.02.2027







READ BEFORE ASSEMBLY

CAUTION

- Read carefully and fully understand the instructions before commencing assembly. A supervising adult should also read the instructions if a child assembles the model.
- When assembling this kit, tools including knives used. Extra care should be taken to avoid personal injury.
- Keep out of reach of small children. Children must not be allowed to suck any part, or pull vinyl bag over their heads.

PAINTS REQUIRED

Color info and profiles by Mlig Jimenez

-  Optional
-  Instant Glue for Metal
-  Apply Decal
-  Do Not Cement
-  Drill
-  Be Careful

APPLYING DECALS

1. Clean the model surface with a wet cloth.
2. Cut out each decal design from sheet, and dip it in tepid water for 15~20 sec.
3. Hold the backing sheet edge and slide decal onto the model.
4. Move decal into position by wetting decal with finger.
5. Press decal gently down with a soft cloth until excess water and air bubbles are gone.

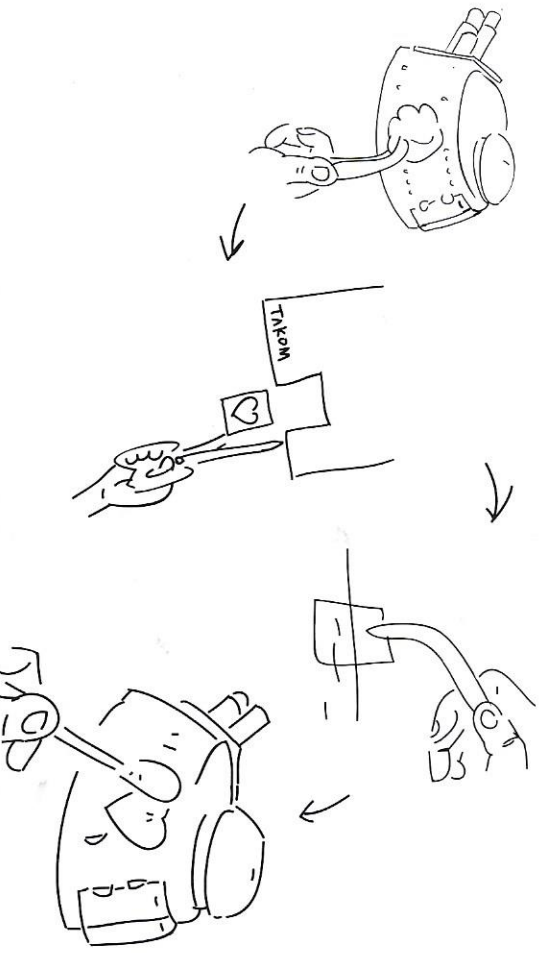

REMOVING PE

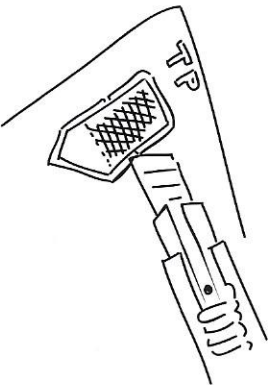

Be careful not to hurt when removing PE parts.



Secure using instant glue (not included).

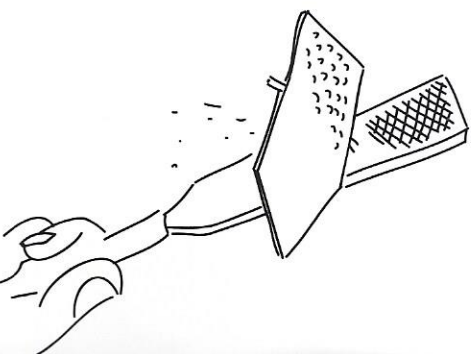

Finish using file.

PARTS

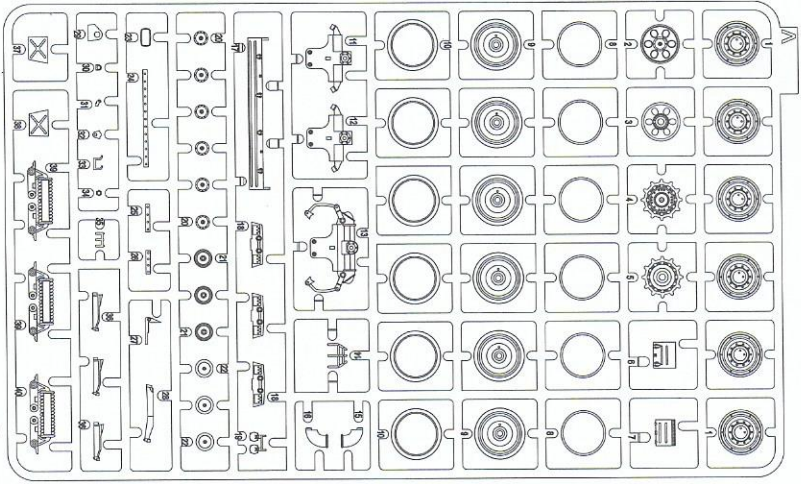

X2

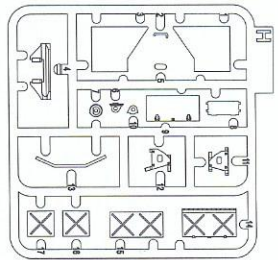
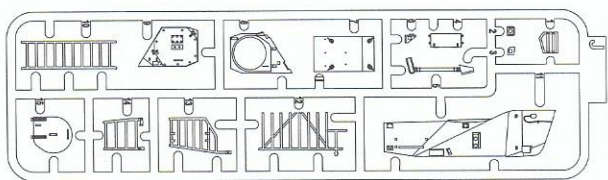
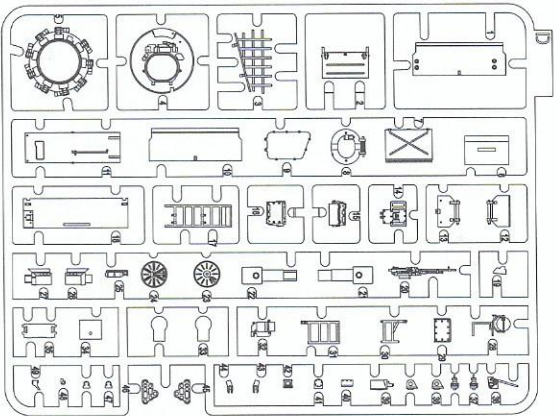
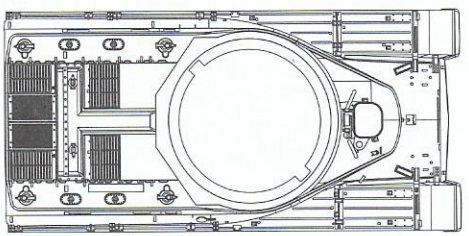
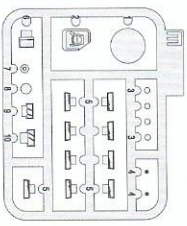
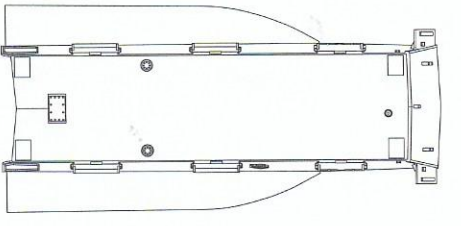
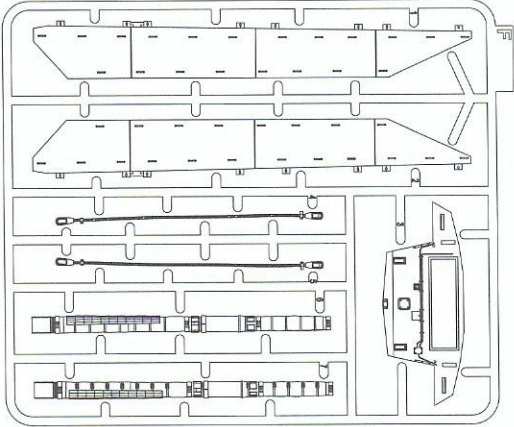
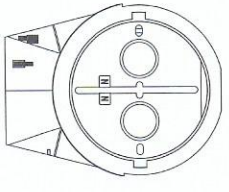
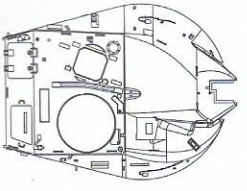

X6

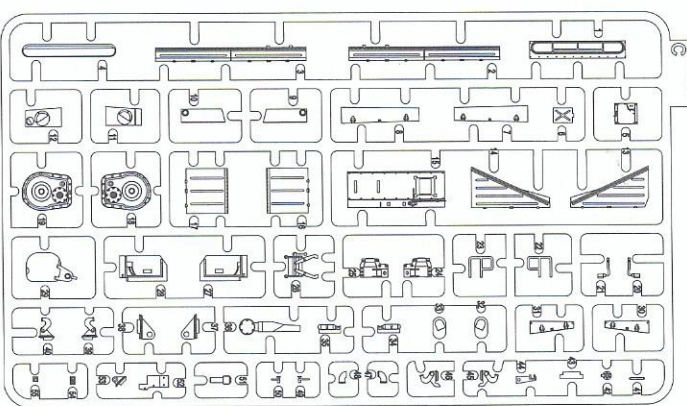
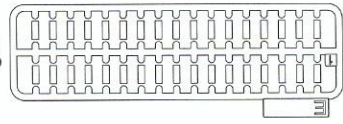

Gun Mask

Poly cap
X2

4333
4334
4335
4336
4337
4338
4339
4340
4341
4342
4343
4344
4345
4346
4347
4348
4349
4350
4351
4352
4353
4354
4355
4356
4357
4358
4359
4360
4361
4362
4363
4364
4365
4366
4367
4368
4369
4370
4371
4372
4373
4374
4375
4376
4377
4378
4379
4380
4381
4382
4383
4384
4385
4386
4387
4388
4389
4390
4391
4392
4393
4394
4395
4396
4397
4398
4399
4400
4401
4402
4403
4404
4405
4406
4407
4408
4409
4410
4411
4412
4413
4414
4415
4416
4417
4418
4419
4420
4421
4422
4423
4424
4425
4426
4427
4428
4429
4430
4431
4432
4433
4434
4435
4436
4437
4438
4439
4440
4441
4442
4443
4444
4445
4446
4447
4448
4449
4450
4451
4452
4453
4454
4455
4456
4457
4458
4459
4460
4461
4462
4463
4464
4465
4466
4467
4468
4469
4470
4471
4472
4473
4474
4475
4476
4477
4478
4479
4480
4481
4482
4483
4484
4485
4486
4487
4488
4489
4490
4491
4492
4493
4494
4495
4496
4497
4498
4499
4500

X200

PE

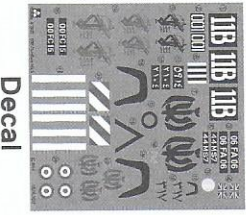
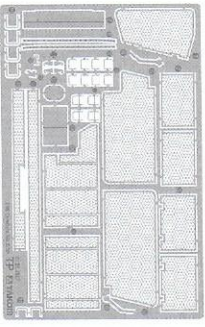

Decal

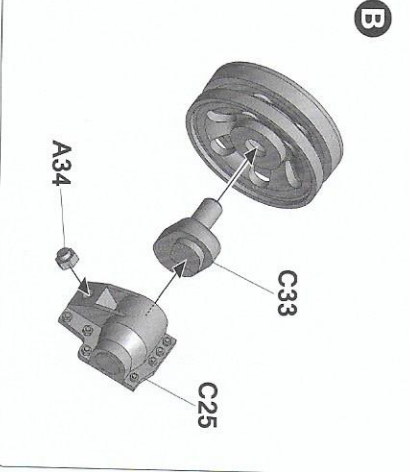
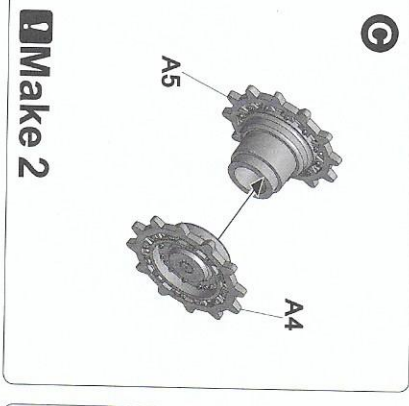
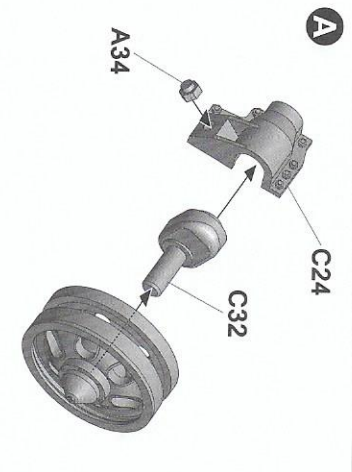
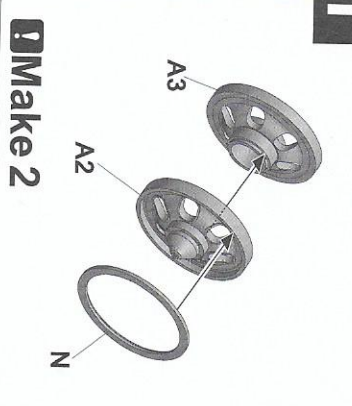

Make 2

Make 2

Make 2

Make 2

Make 2

Make 2

Make 2

Make 2

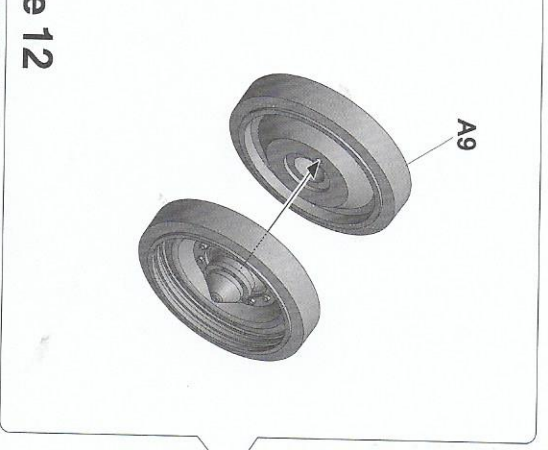
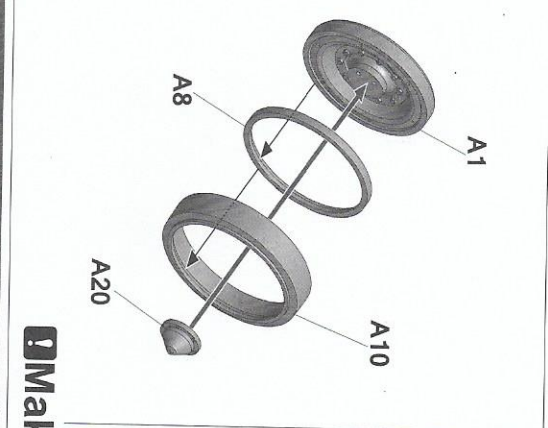

Make 12

Make 12

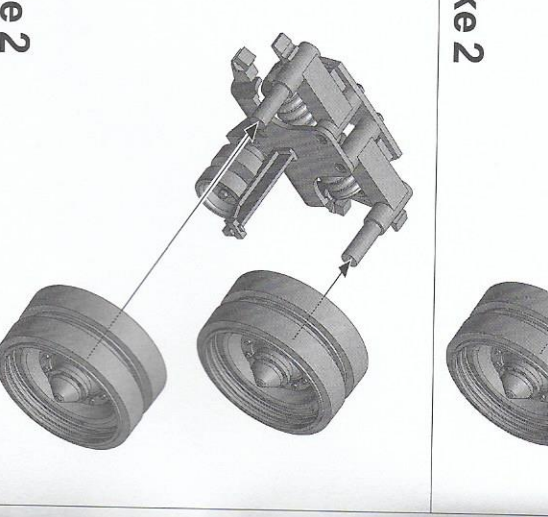
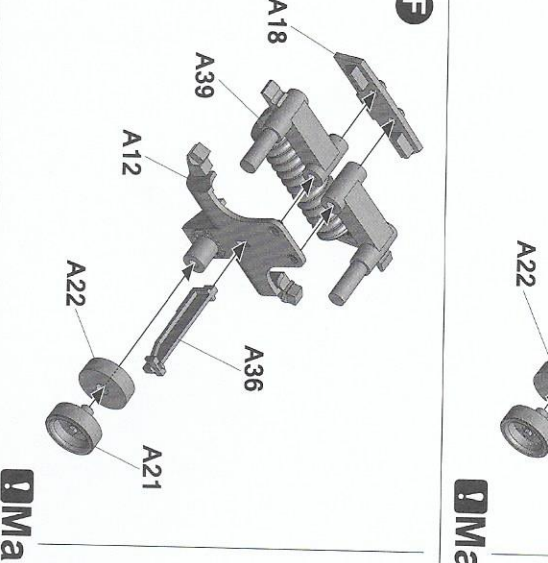

Make 2

Make 2

Make 2

Make 2

Make 2

Make 2

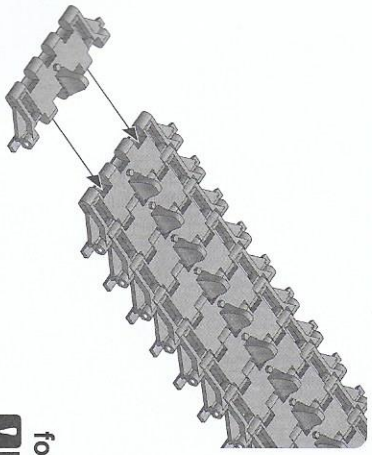
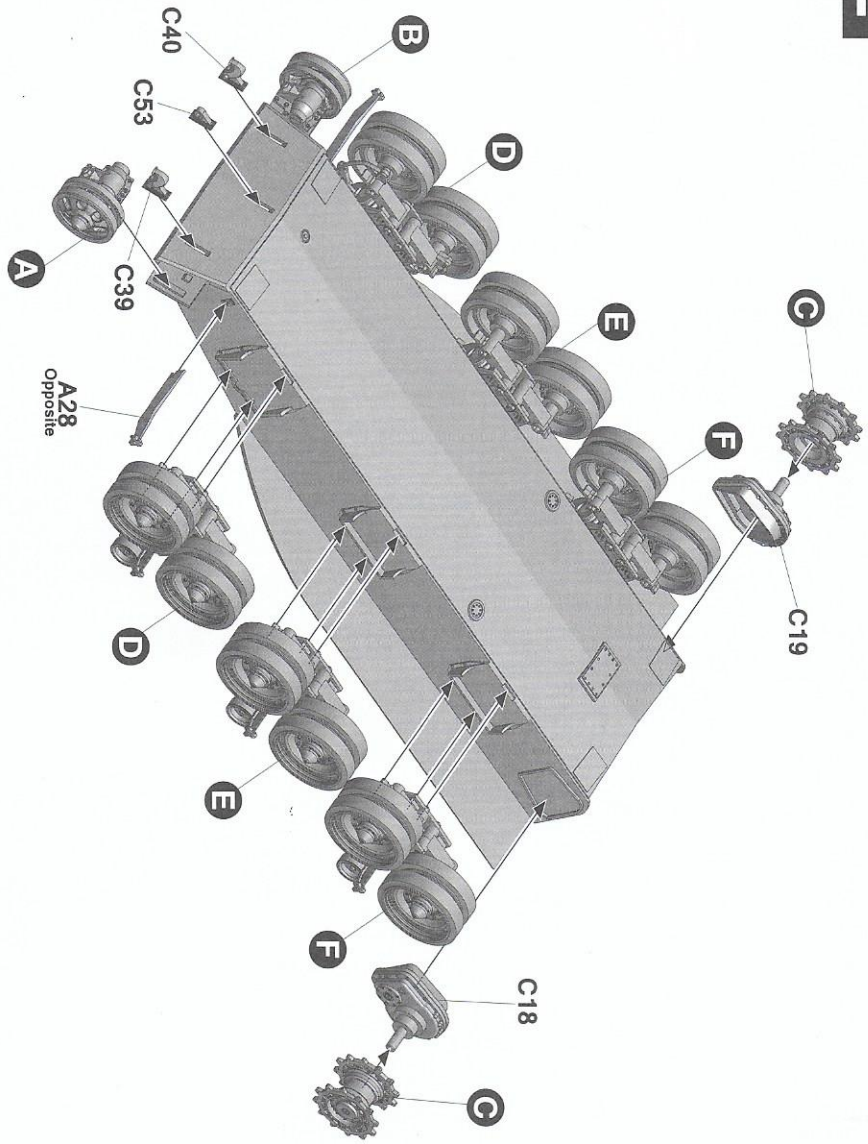

for one side
Make 97

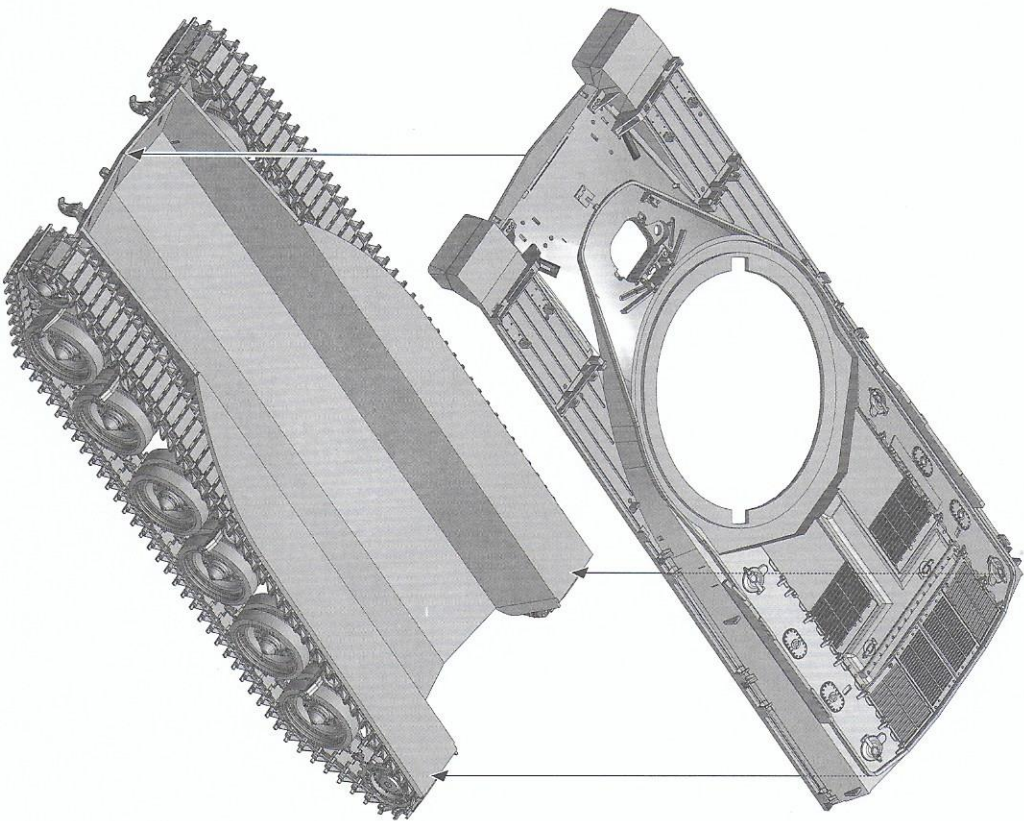
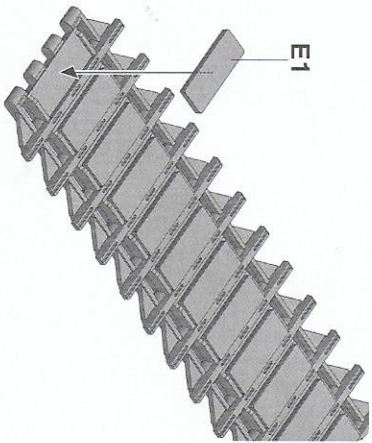

4

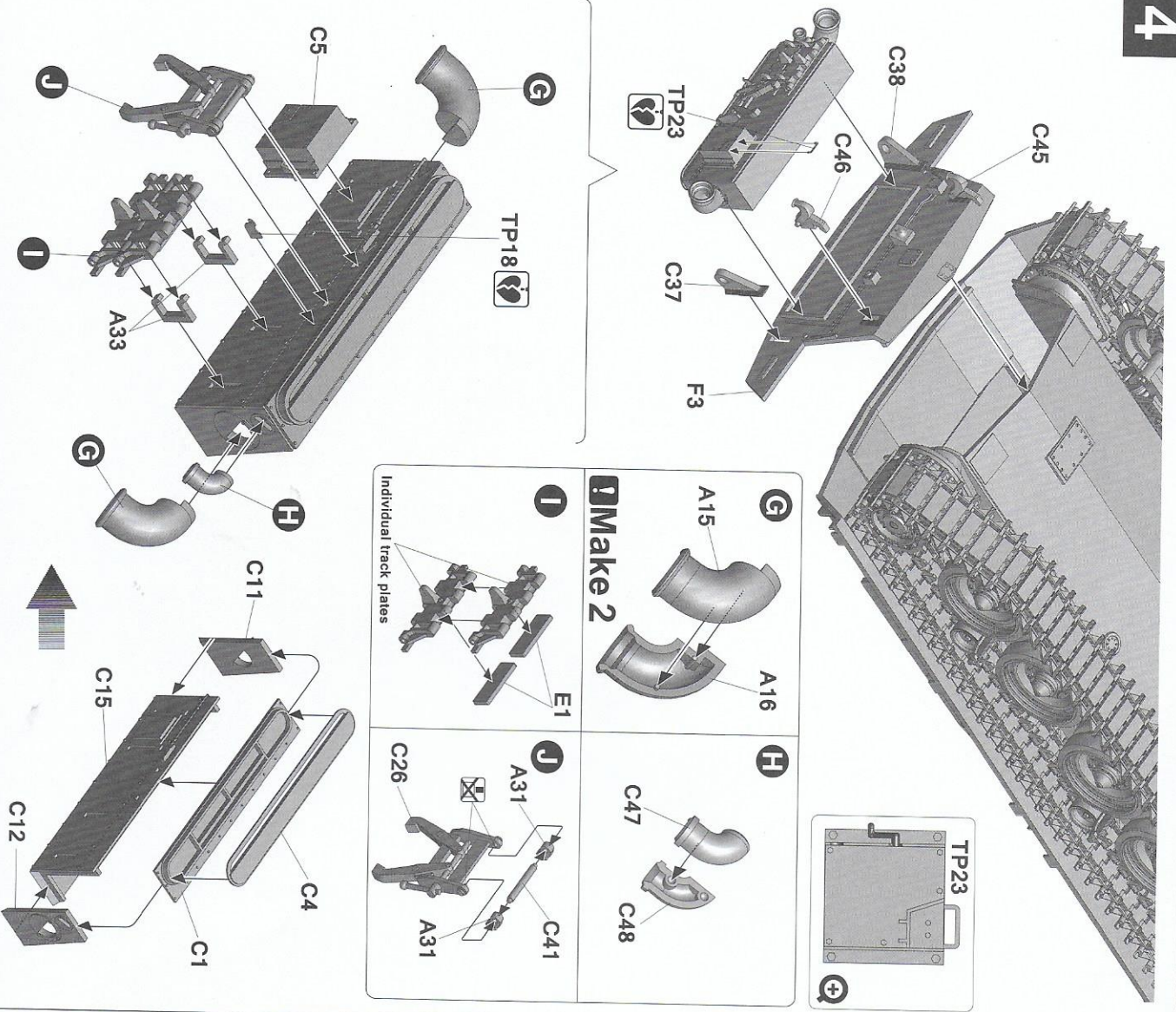

6

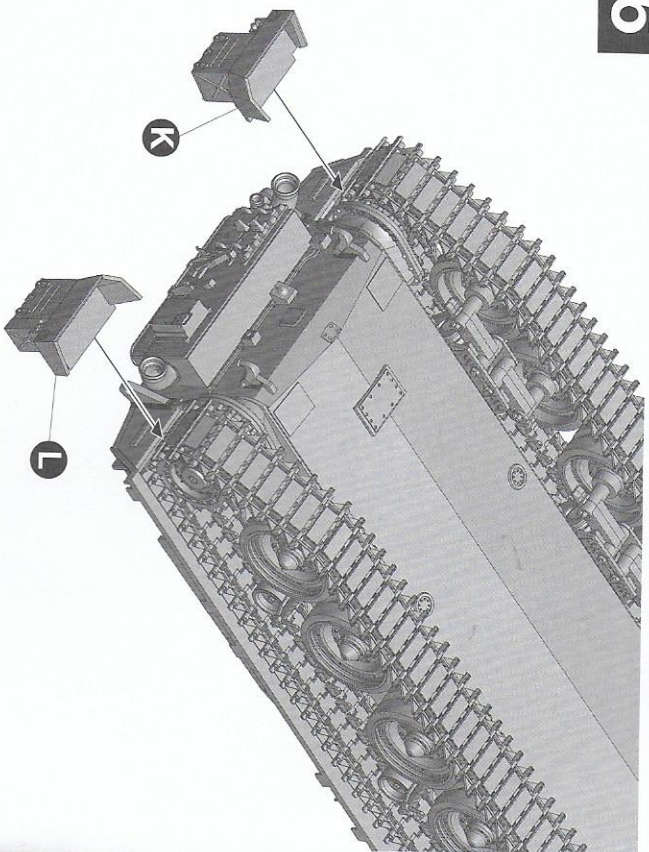

5

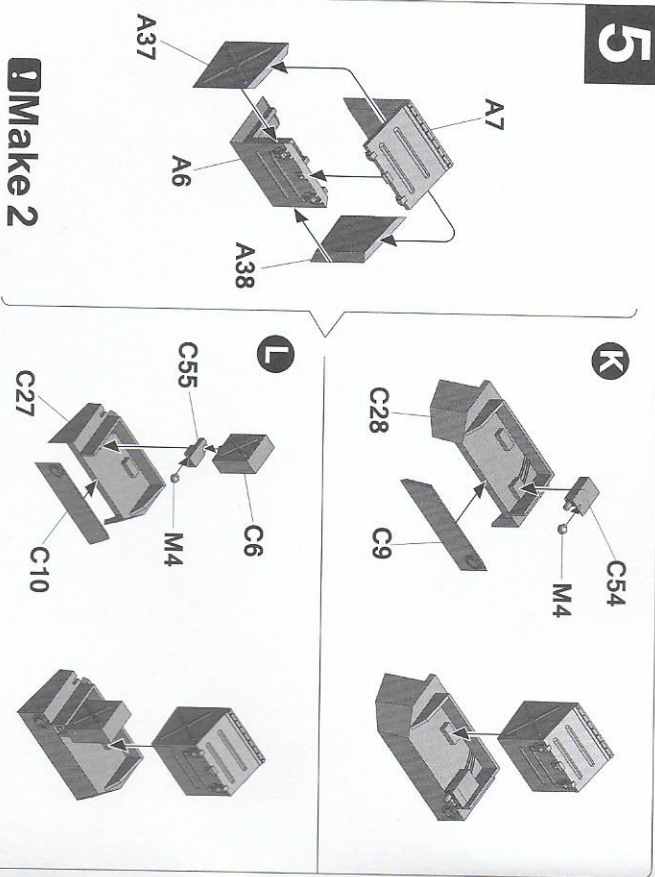

5

7

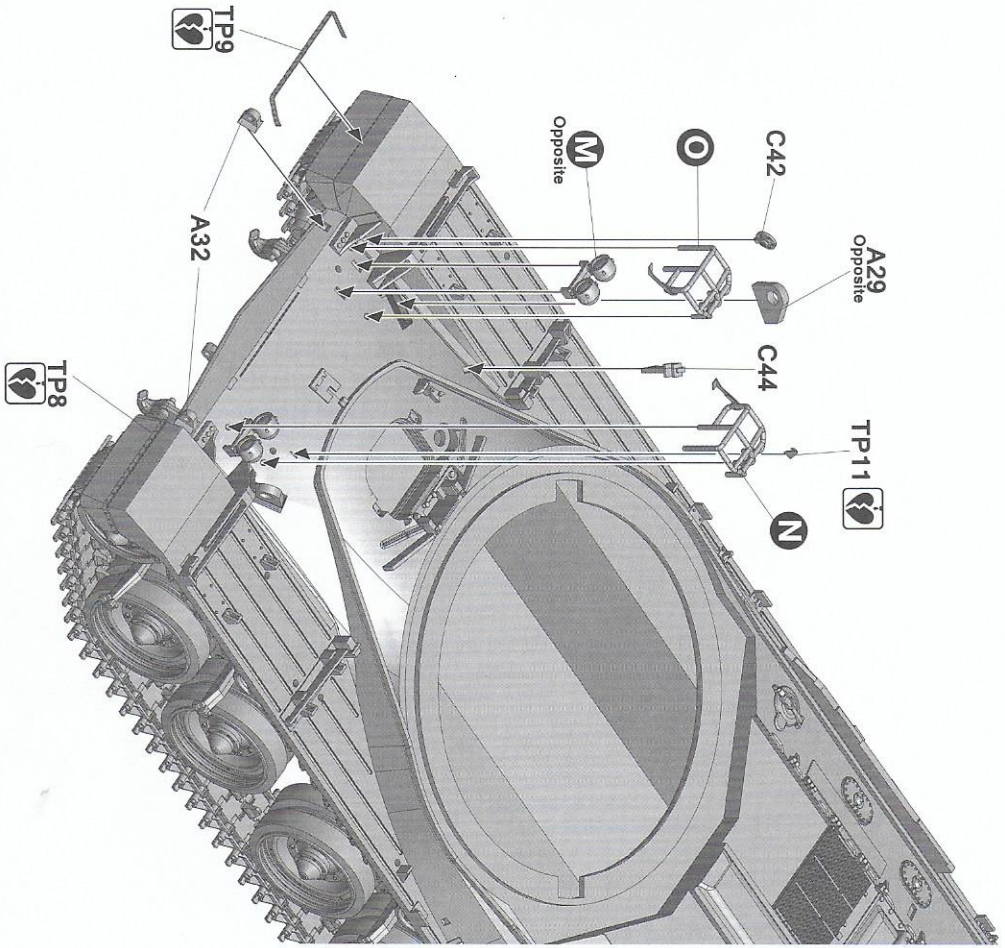
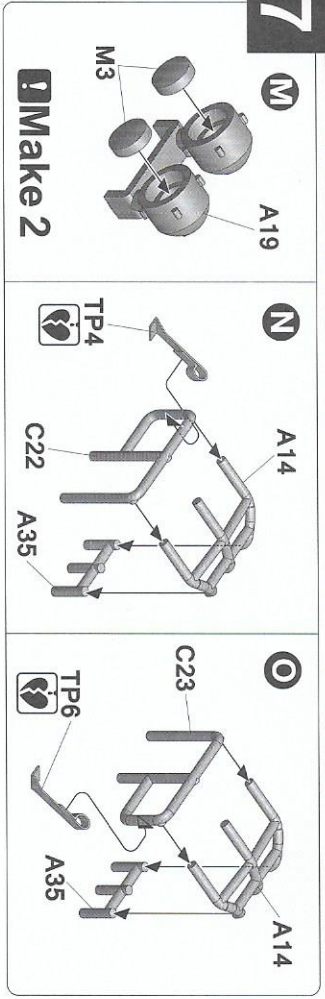

8

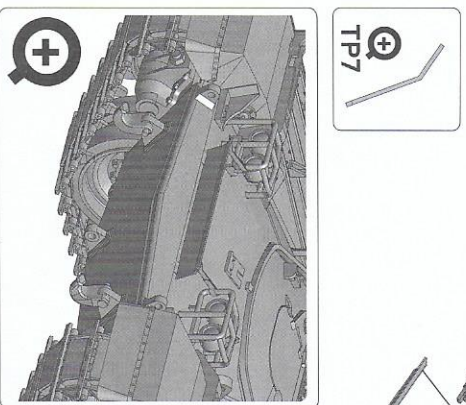
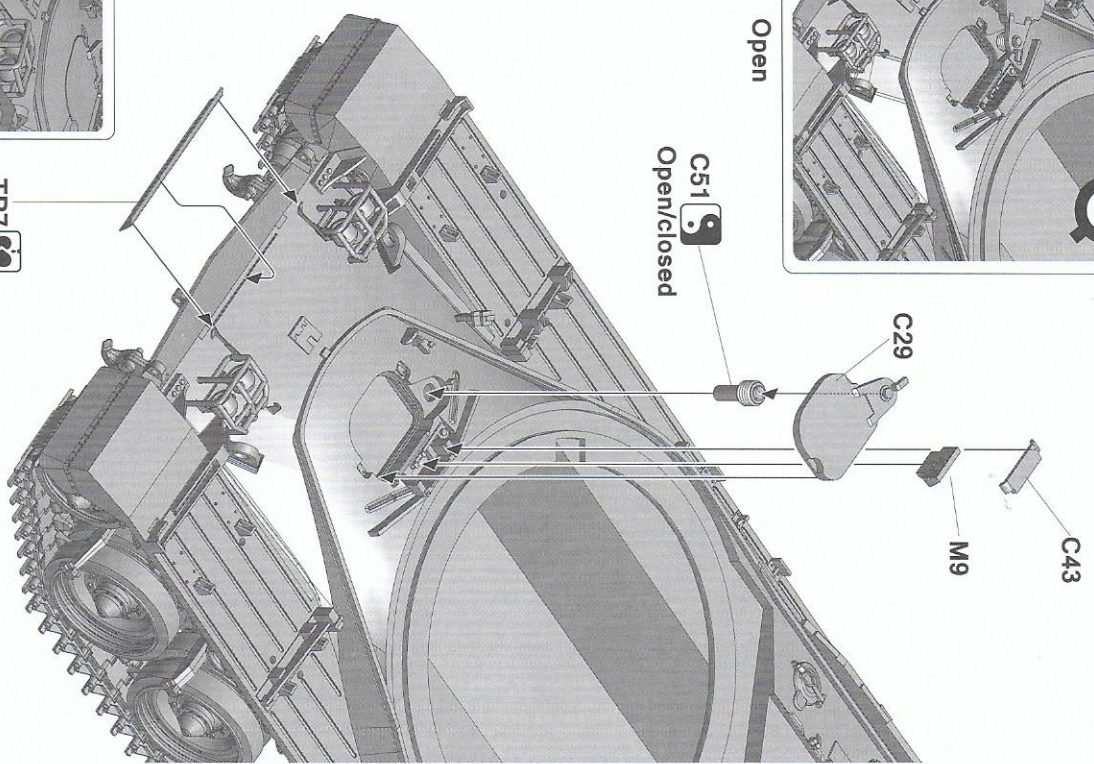
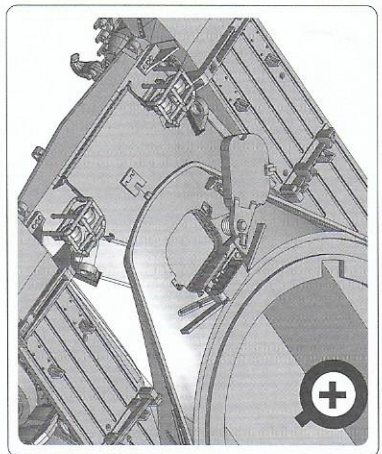

6

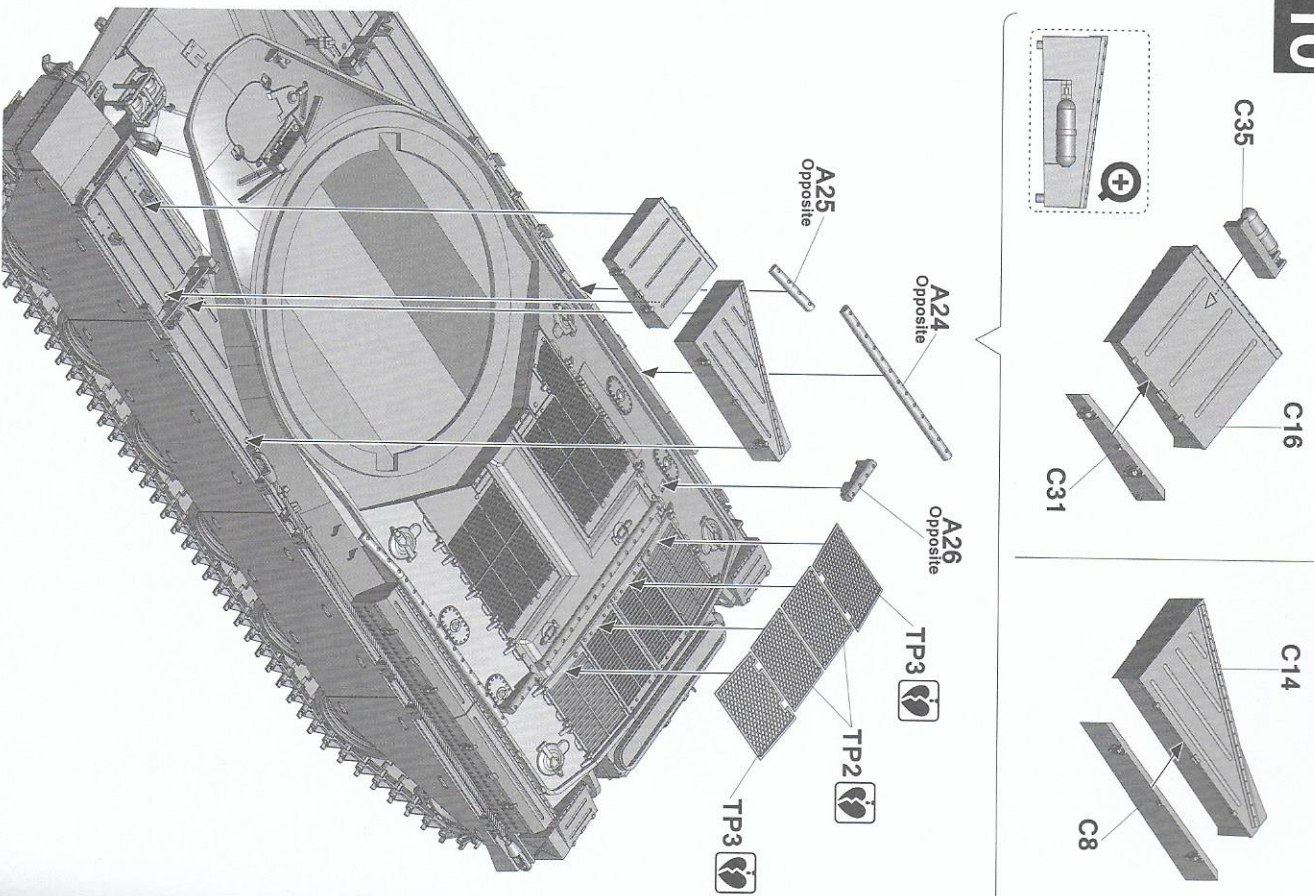
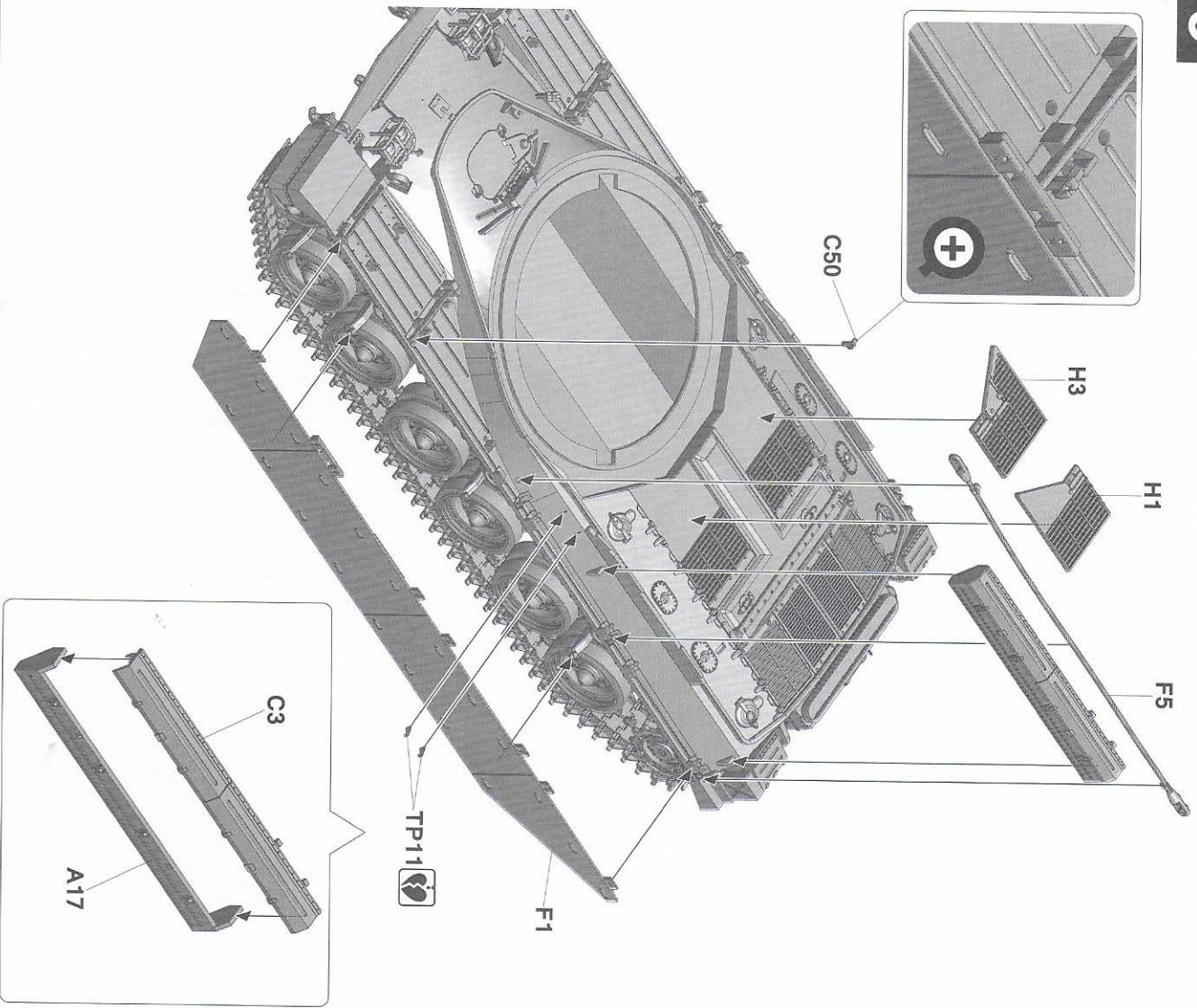

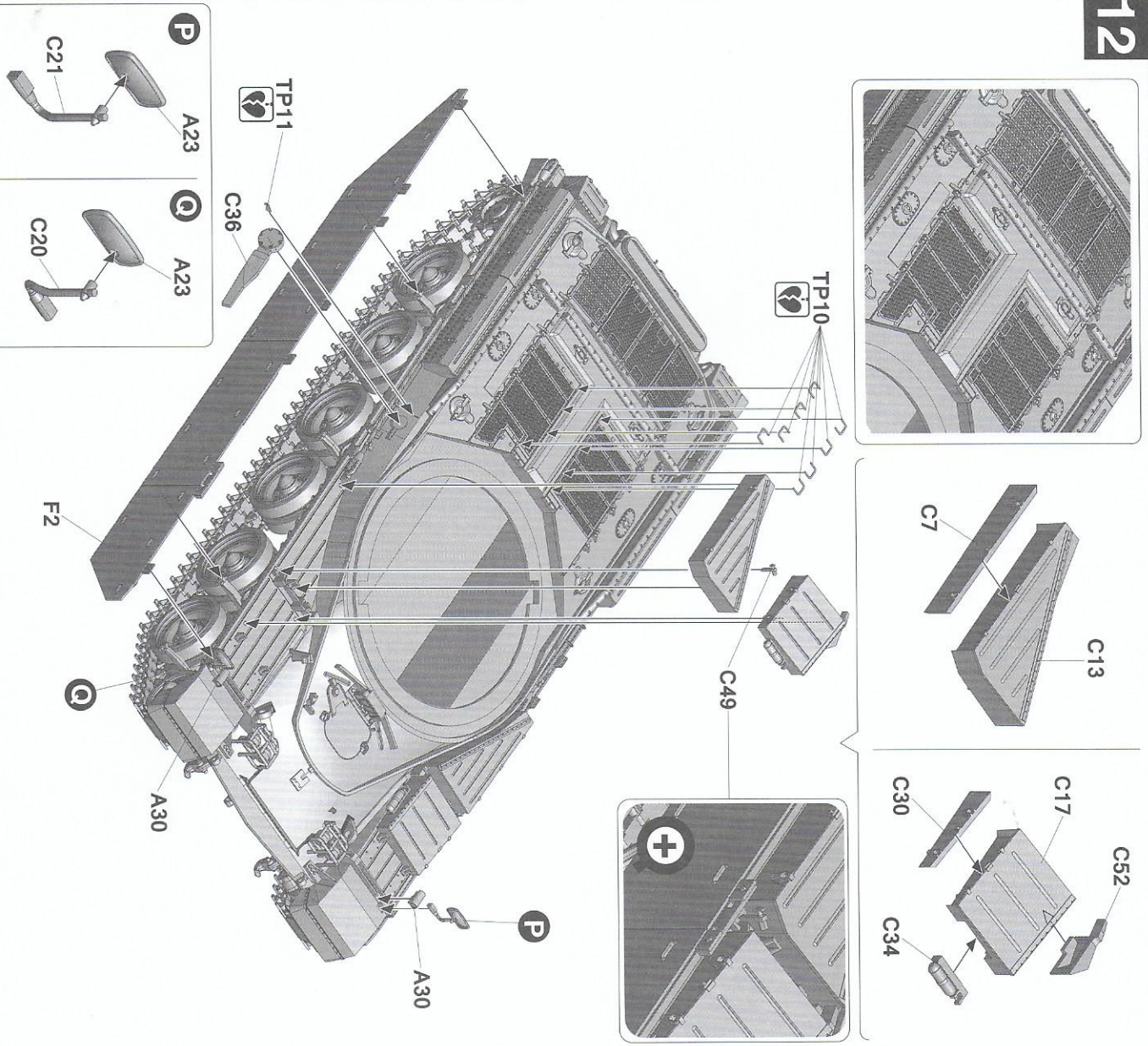
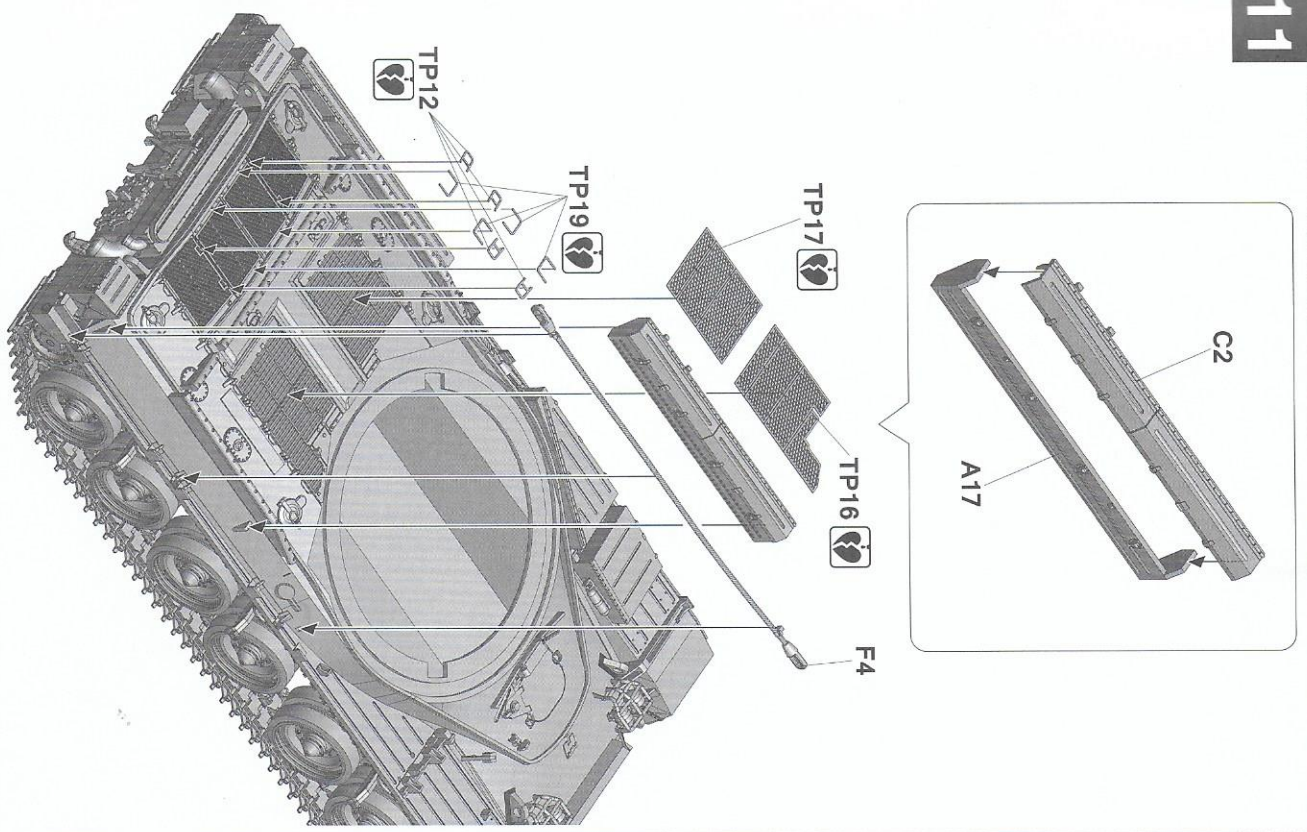

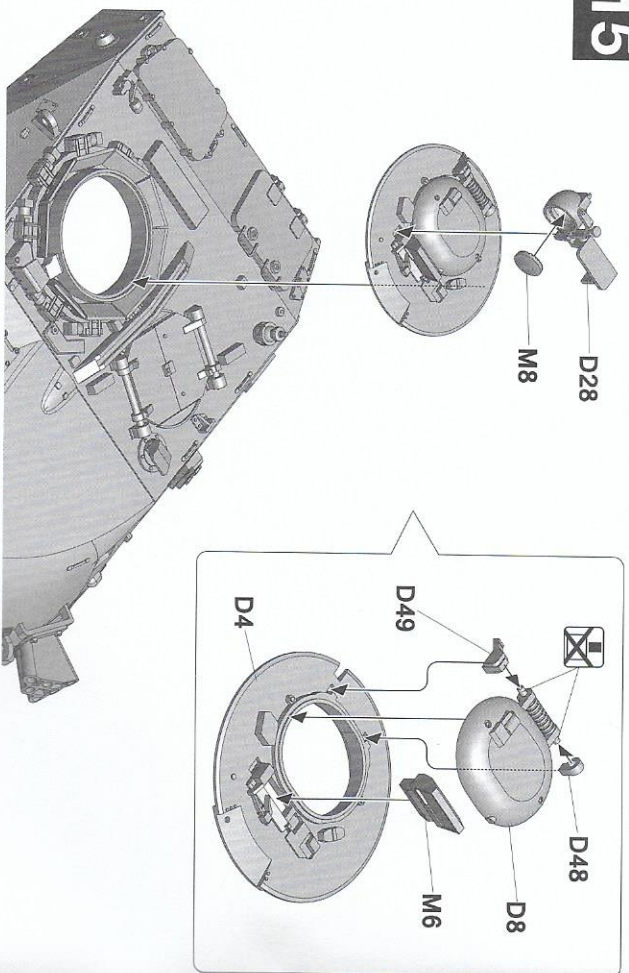
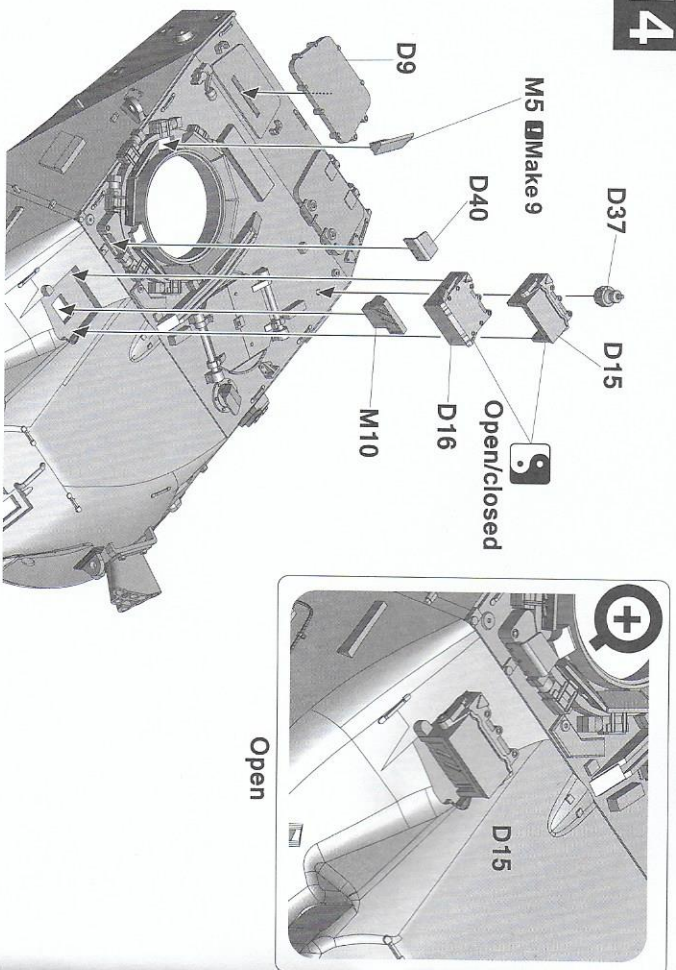
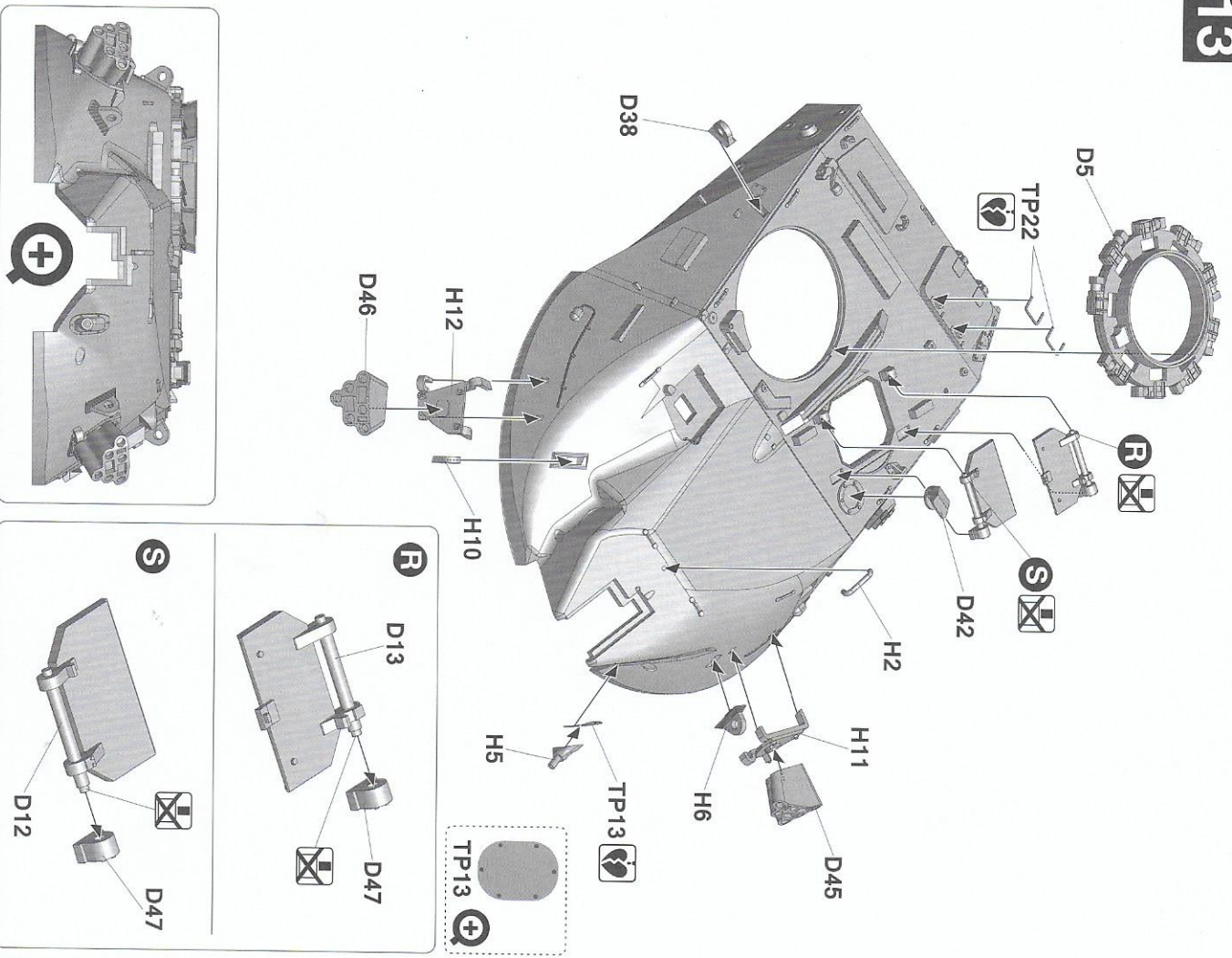

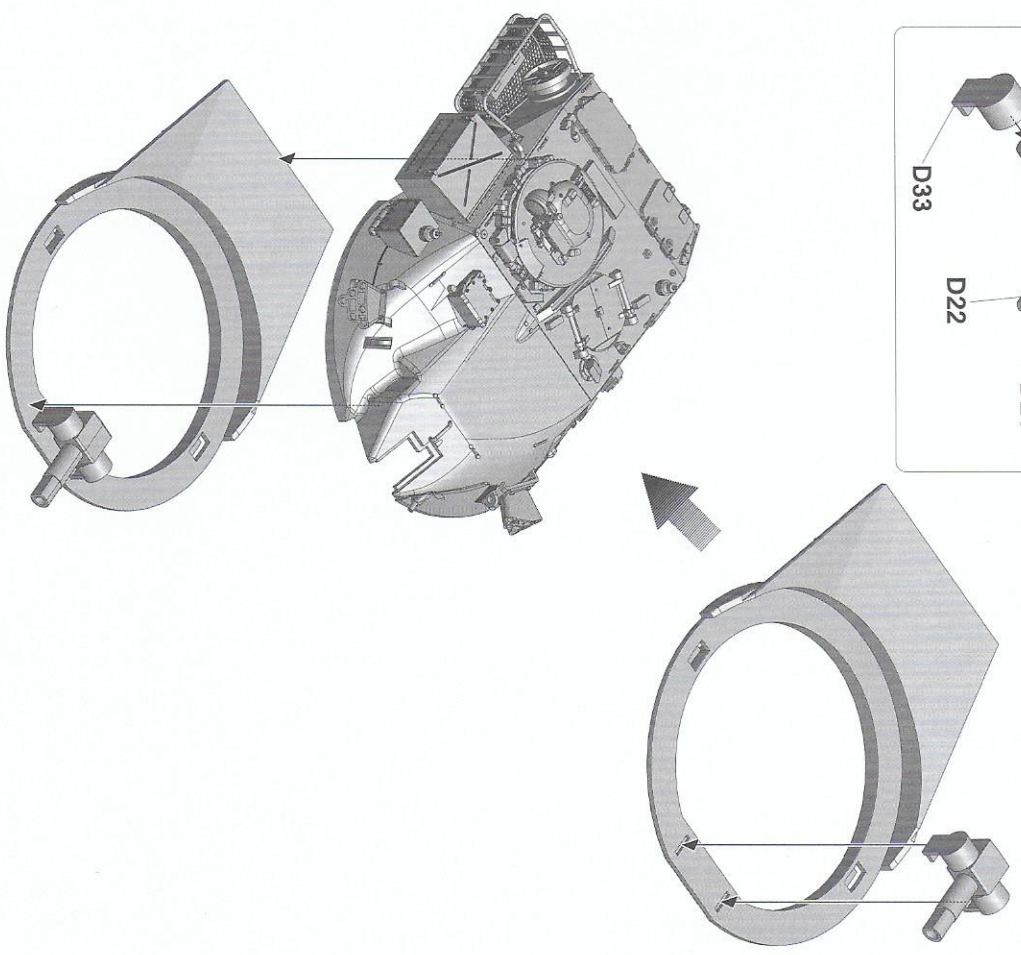
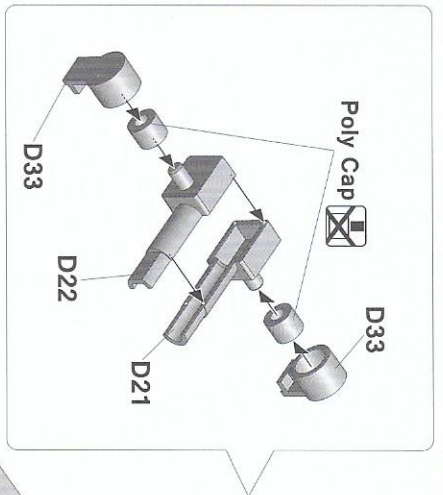
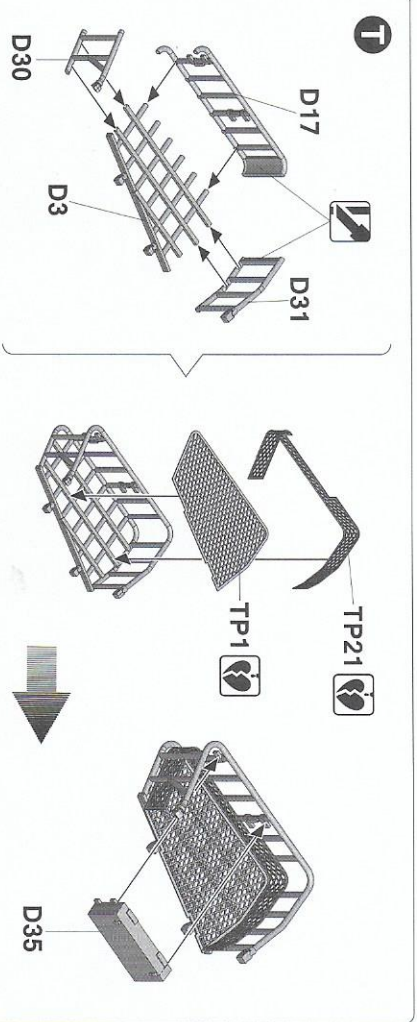
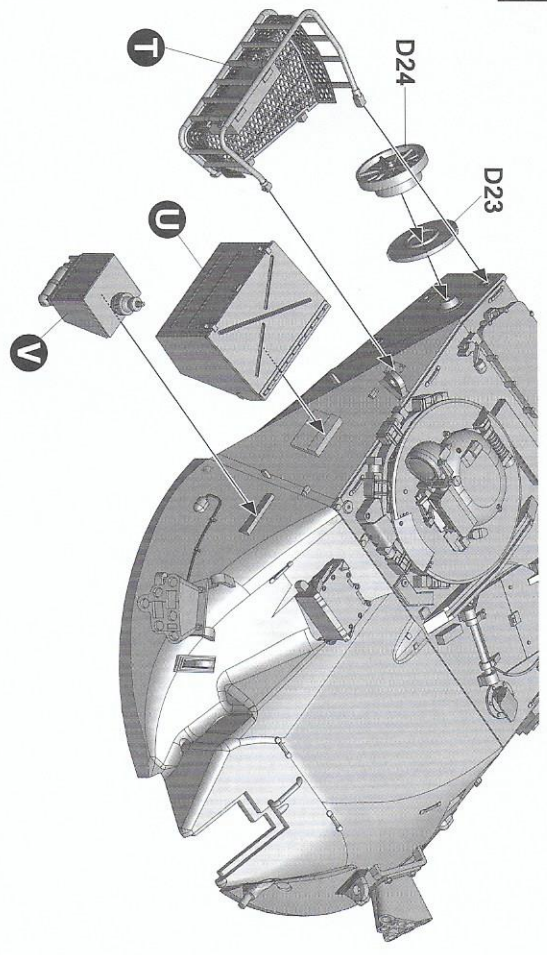

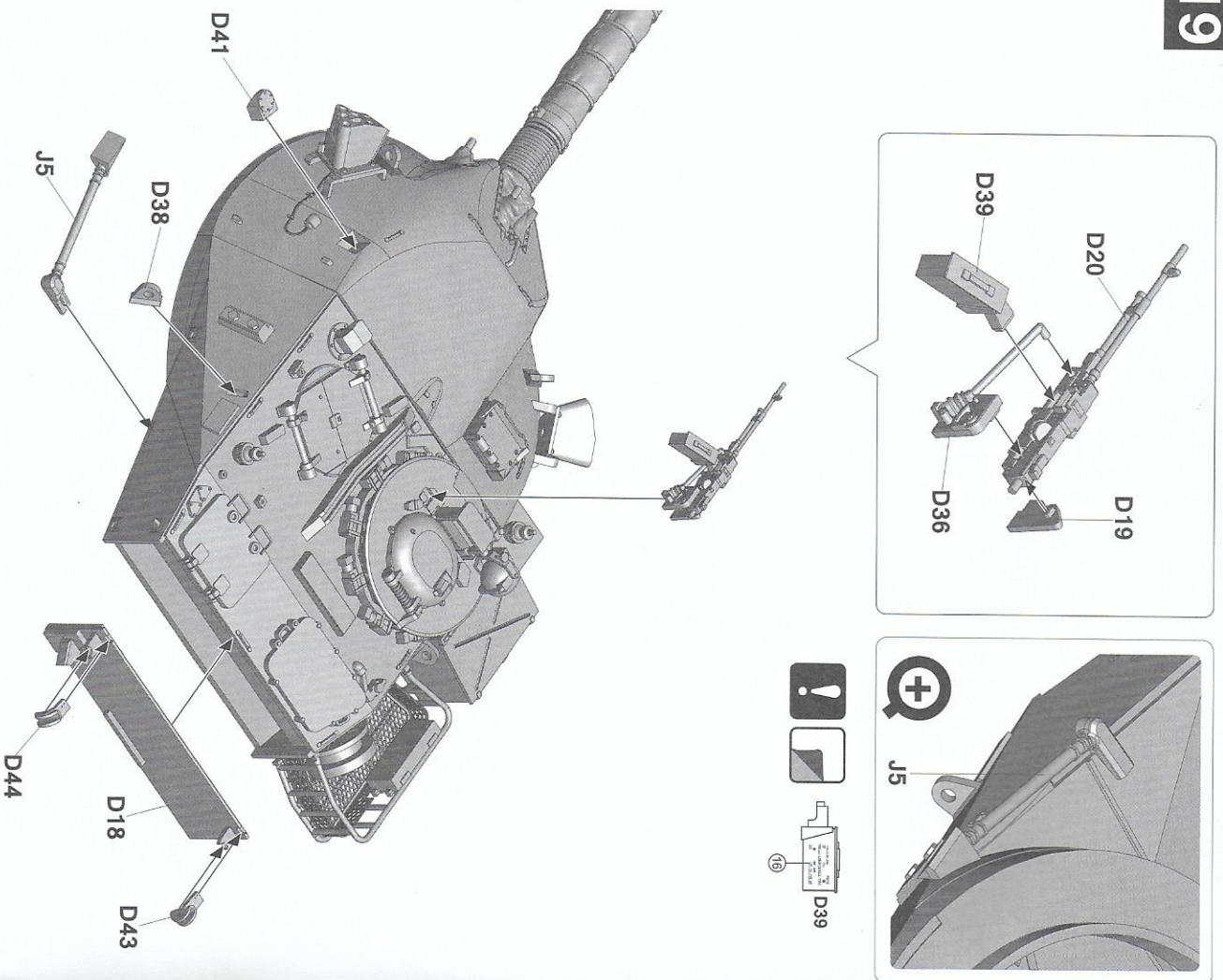
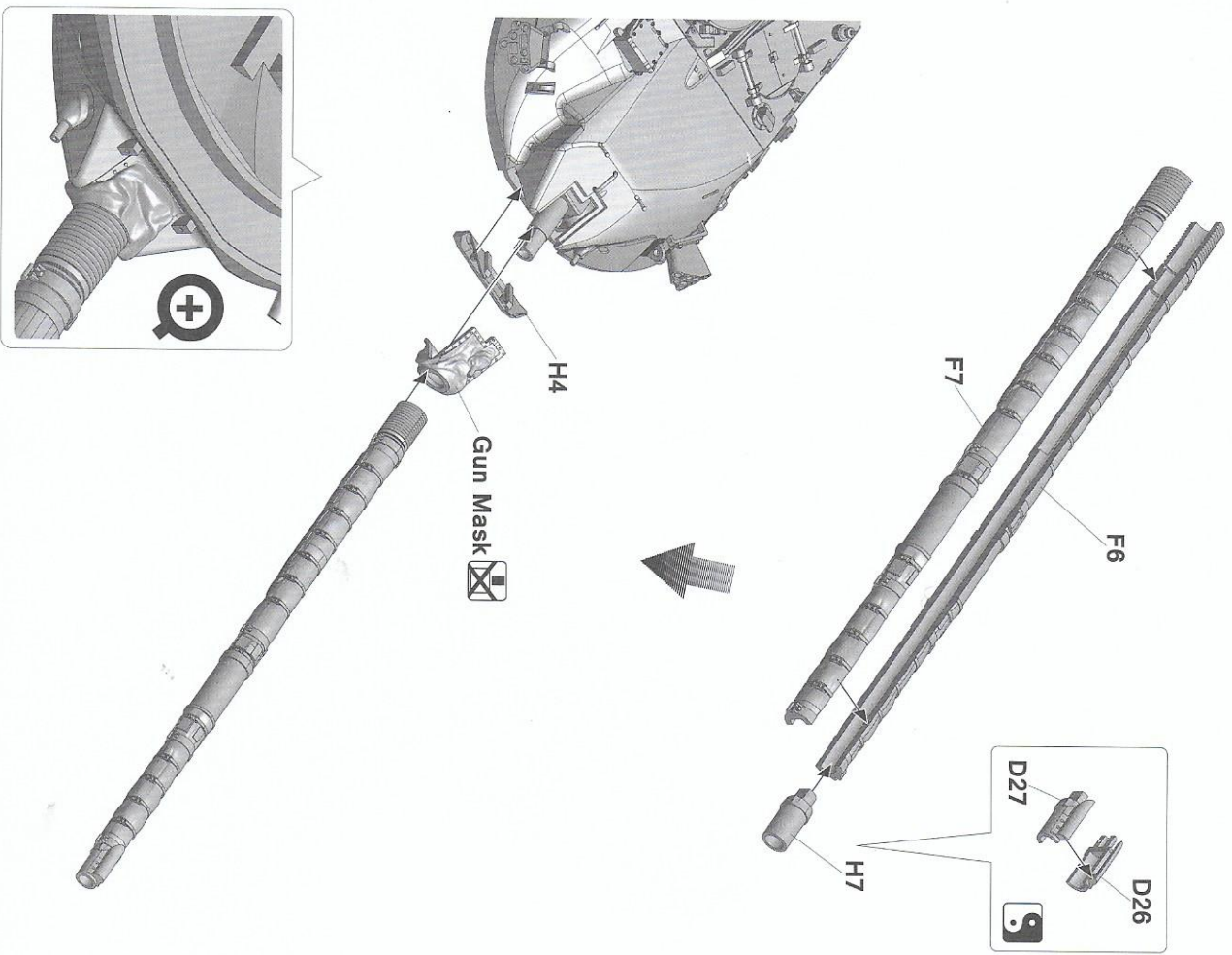

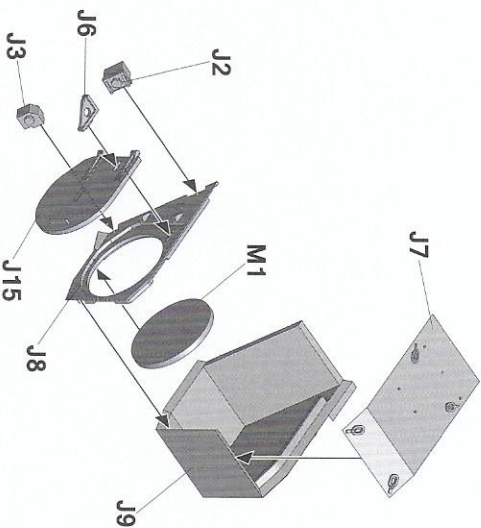
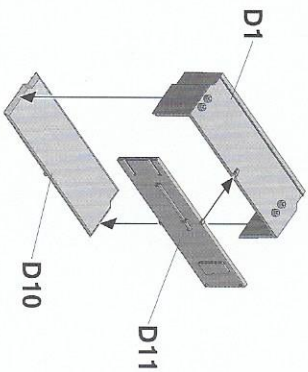
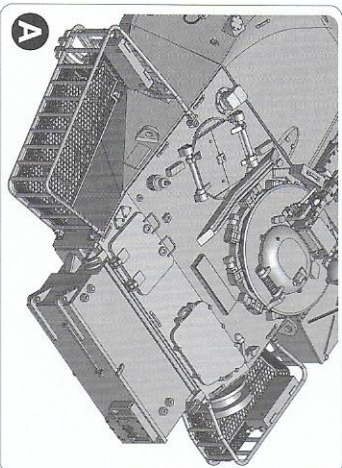
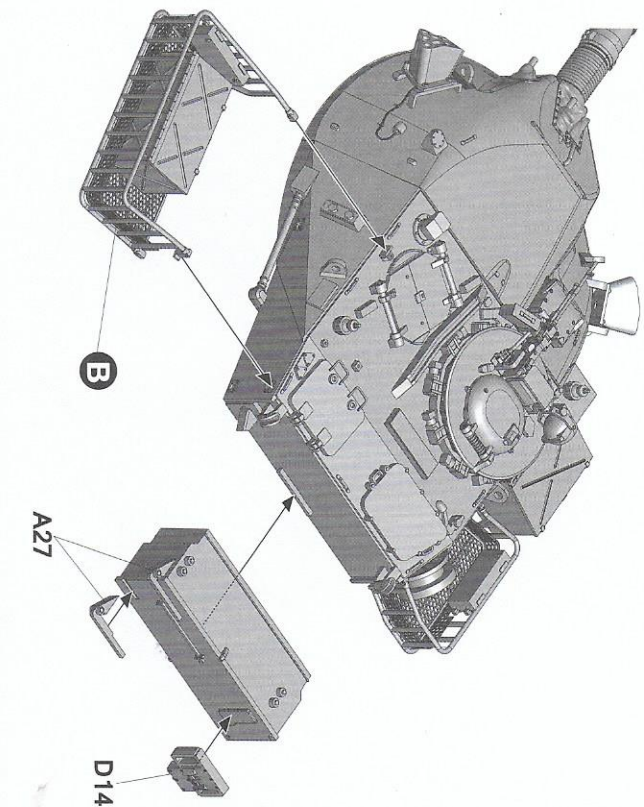
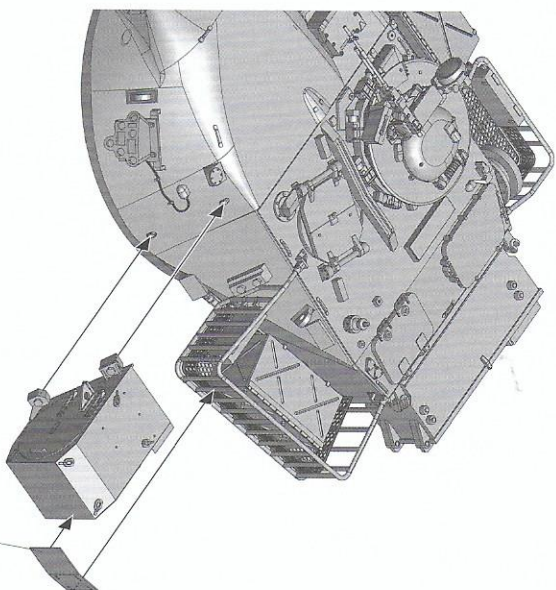
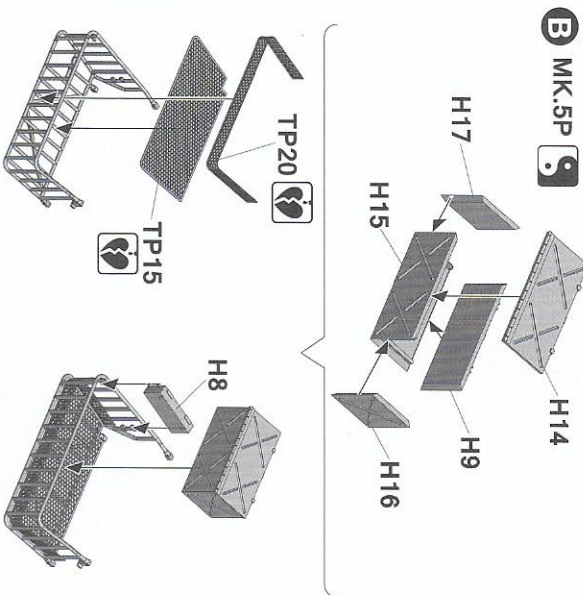
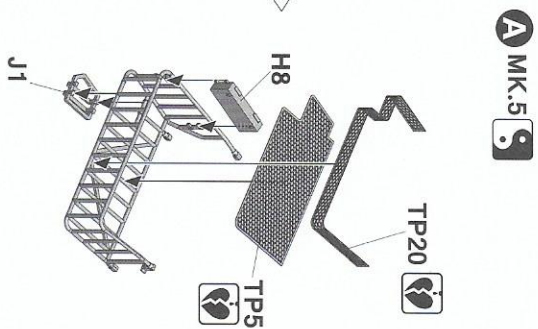
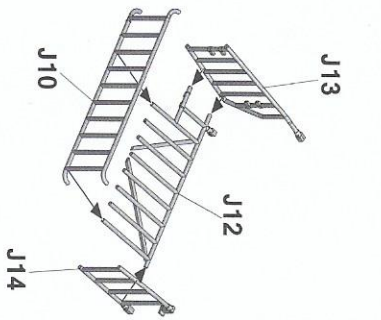

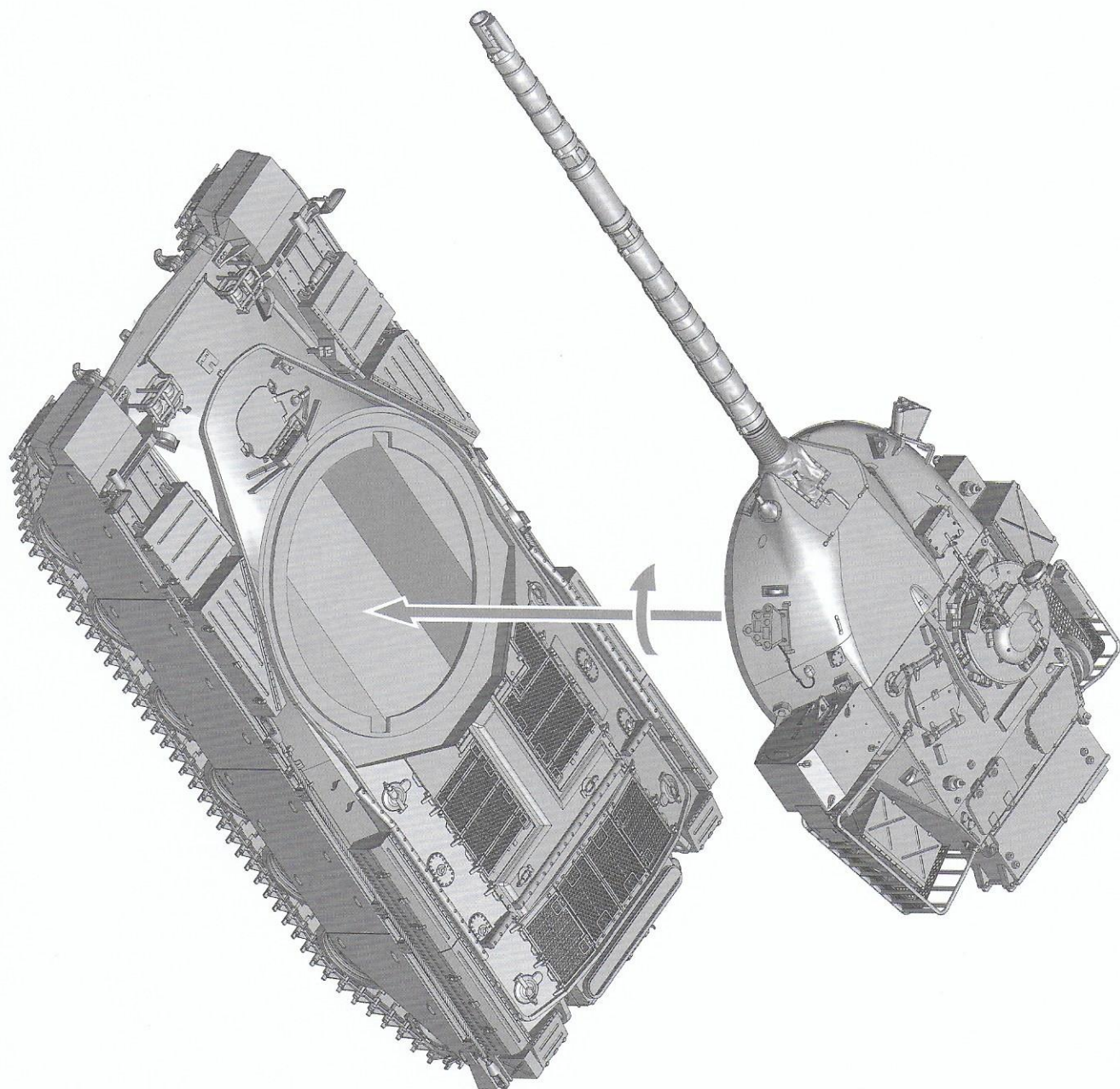

03.03.2027



CHIEFTAIN MK.5/5P



Color info and profiles by

Painting and Marking Guide

D squadron, 4/7th Dragoon Guards, Berlin 1983

▲ AMIG 033 Rubber & Tire ▲ AMIG 041 Dark Rust ▲ AMIG 043 Gun Metal ▲ AMIG 044 Crystal Glass

▲ AMIG 093 Crystal Smoke ▲ AMIG 097 Crystal ▲ AMIG 046 Gun Black ▲ AMIG 090 Gun White

▲ AMIG 070 Medium Brown ▲ AMIG 084 NATO Green ▲ AMIG 210 Grey Blue

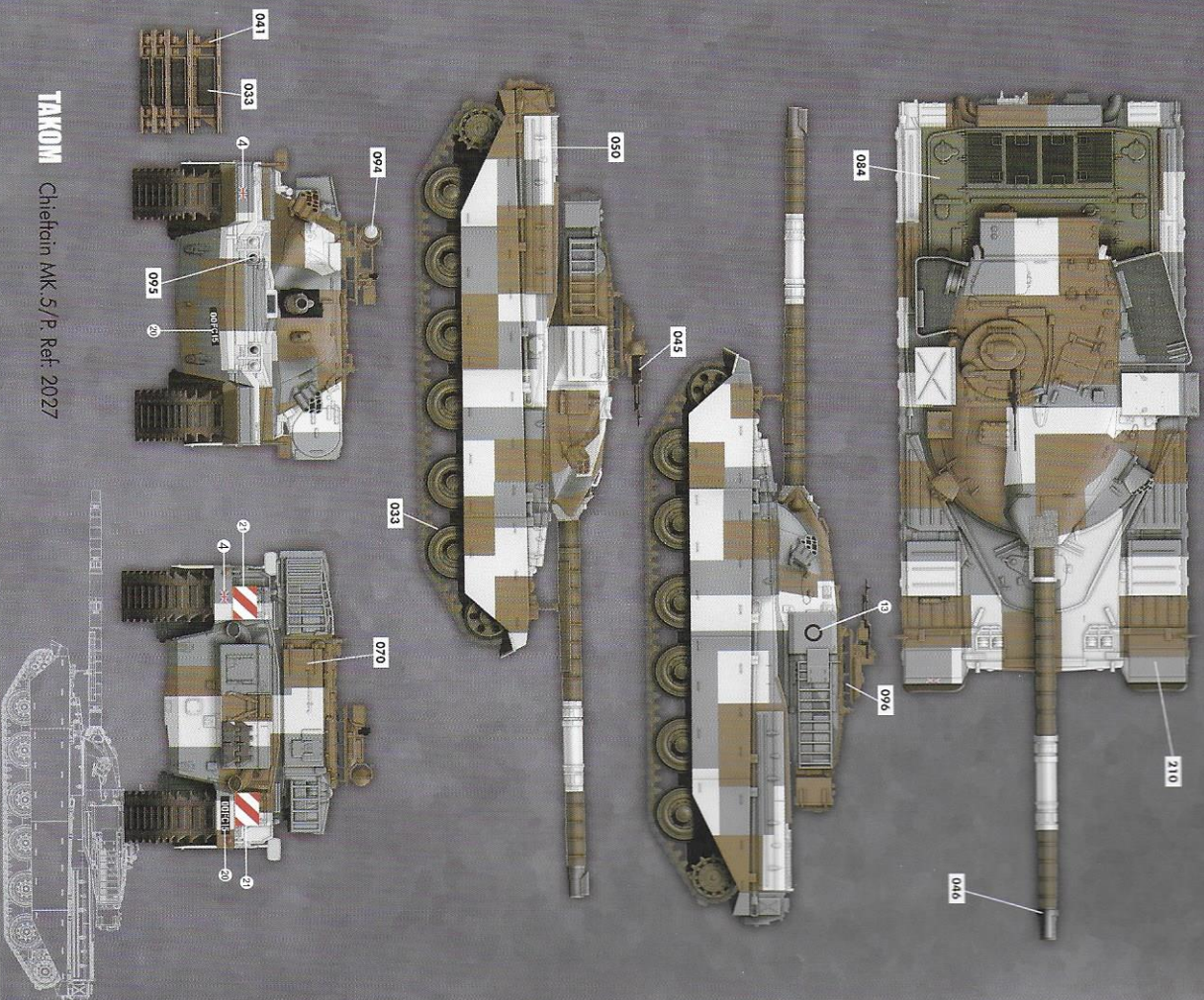

BRITISH MAIN BATTLE TANK

CHIEFTAIN Mk.5/5P

- ▲ DETAILED STATIC DISPLAY PLASTIC MODEL
- ▲ PE & CLEAR PARTS INCLUDED
- ▲ INDIVIDUAL TRACKS
- ▲ 7 TYPES OF MARKINGS
- ▲ THE GUN CAN PITCH
- ▲ ALL HATCHES CAN BE BUILT IN OPEN OR CLOSED POSITION

▲ READY TO ASSEMBLE PRECISION MODEL KIT ▲ INTENDED FOR COLLECTORS OF AGE 14 YEARS AND ABOVE ▲ MODEL MAY VARY FROM IMAGE ON BOX ▲ CEMENT AND PAINT NOT INCLUDED

2 In 1



1/35 No.2027



TAKOM Chieftain MK.5/P Ref. 2027



CHIEFTAIN MK.5/5P

Color info and profiles by



Painting and Marking Guide

Iranian MK.5/P, Battle of Sodomach (preceding the liberation of Khorramshahr) 242nd Battalion, 4th Brigade, 21st Infantry Division, Operation "Bait-ol-Mogaddas", May 1983

AMIG 033 Rubber & Tires

AMIG 041 Dark Rust

AMIG 043 Gun Metal

AMIG 044 Crystal Glass

AMIG 035 Crystal Smoke

AMIG 036 Crystal Periscope Green

AMIG 037 Yellow Grey

AMIG 040 Army Black

AMIG 206 FS 34075 (R5 641)

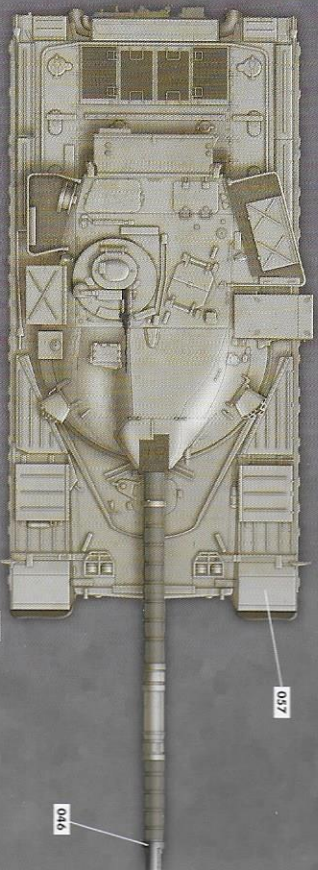

017



016

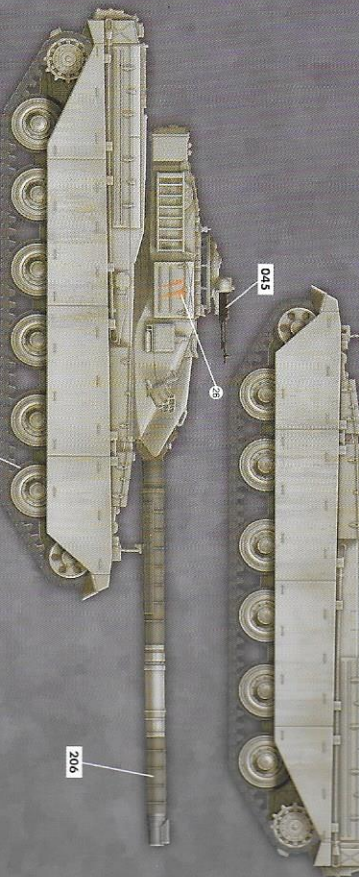

015

033

206

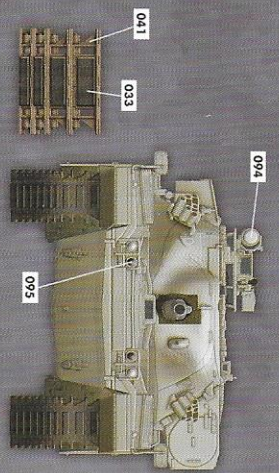

041

033

094

095

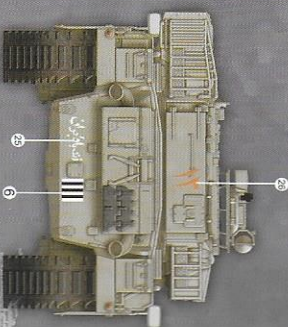

020

021

022

023

024

025

026



TAKOM Chieftain MK.5/P, Ref: 2027



CHIEFTAIN MK.5/5P

Color info and profiles by



Painting and Marking Guide

Kwail MK.5/K, Martyrs Brigade, Operation Desert Storm, 1991

AMIG 033 Rubber & Tires

AMIG 041 Dark Rust

AMIG 045 Gun Metal

AMIG 044 Crystal Glass

AMIG 035 Crystal Smoke

AMIG 036 Crystal Periscope Green

AMIG 039 Desert Sand

AMIG 206 FS 34075 (R5 641)

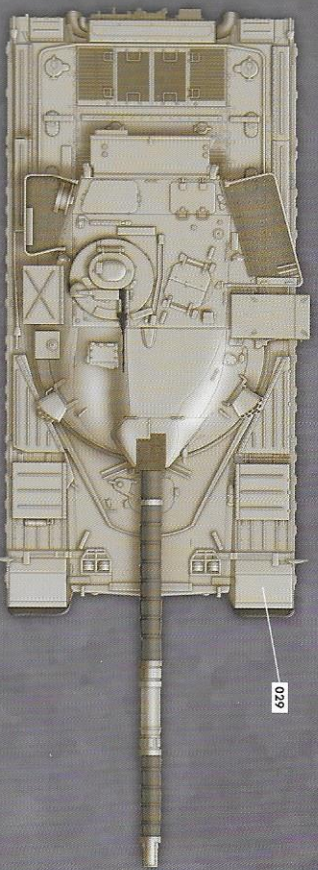

029



028

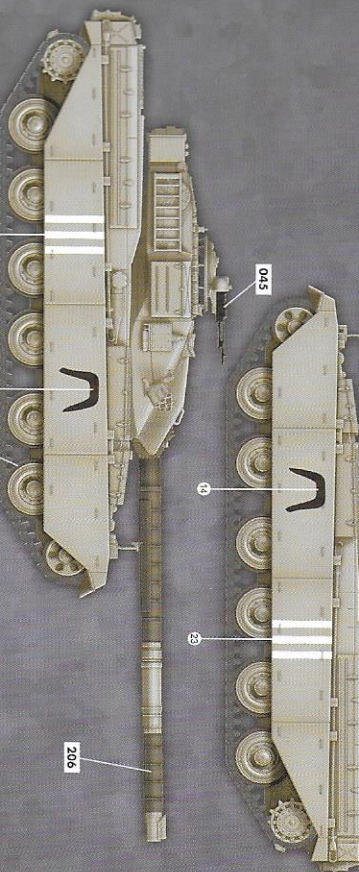

045

046

047

048

049

050

051

052

053

206

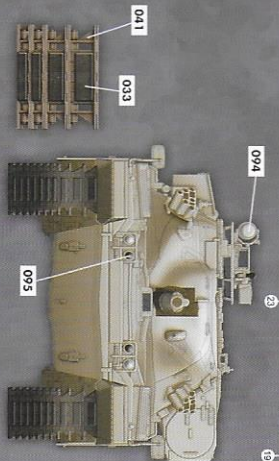

041

033

094

095

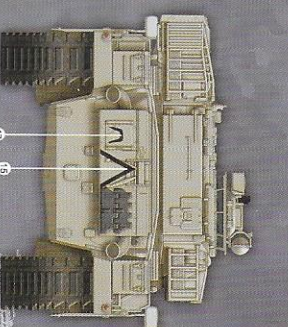

020

021

022

023

024

025

026



TAKOM Chieftain MK.5/P, Ref: 2027



CHIEFTAIN MK.5/5P



Color info and profiles by

Painting and Marking Guide

- AMIG 033** Rubber & Tires
- AMIG 041** Dark Rust
- AMIG 045** Gun Metal
- AMIG 094** Crystal Glass
- AMIG 075** Crystal Smoke
- AMIG 096** Crystal
- AMIG 037** Yellow Grey
- AMIG 046** Metal Black
- AMIG 206** FS 34075 (FS 641)

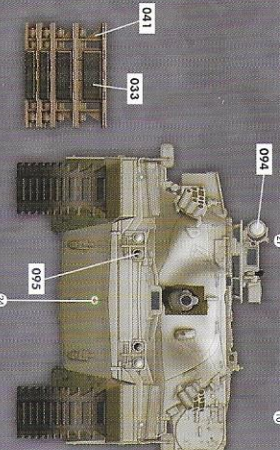
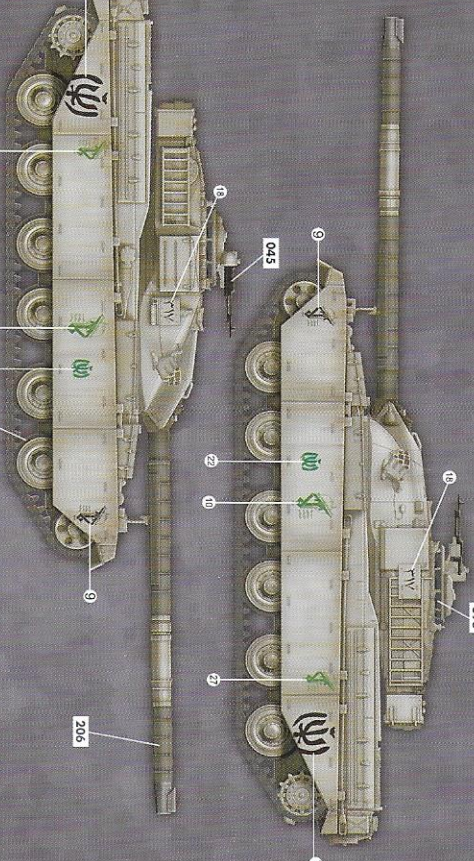
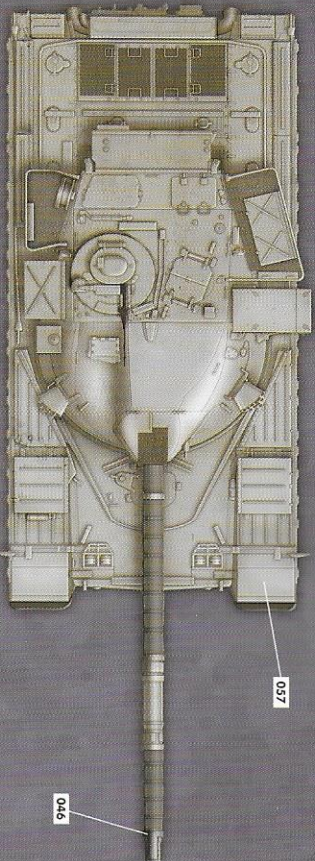

TAKOM Chiefain MK.5/P Ref: 2027



CHIEFTAIN MK.5/5P



Color info and profiles by

Painting and Marking Guide

- AMIG 033** Rubber & Tires
- AMIG 041** Dark Rust
- AMIG 045** Gun Metal
- AMIG 094** Crystal Glass
- AMIG 095** Crystal Smoke
- AMIG 096** Crystal
- AMIG 037** Yellow Grey
- AMIG 046** Metal Black
- AMIG 110** British Brown

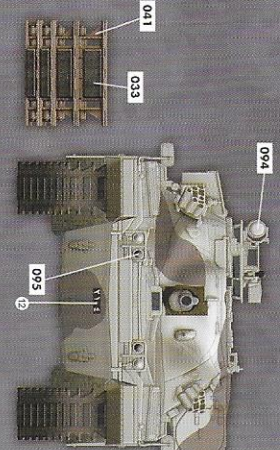
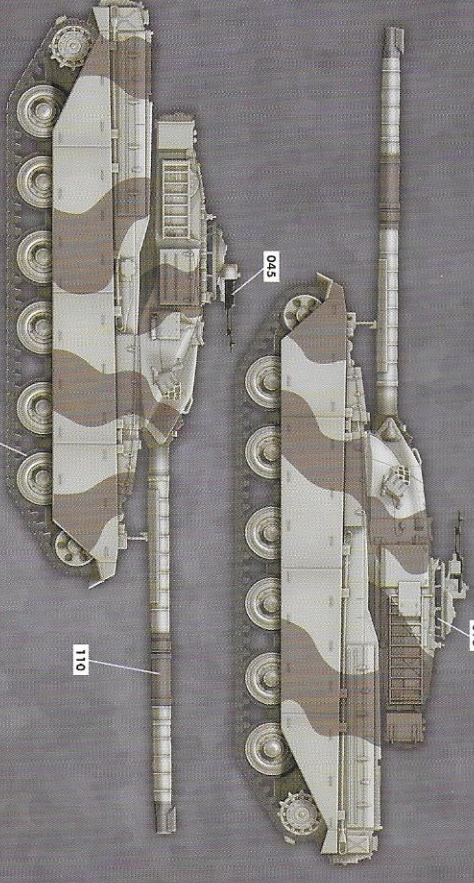
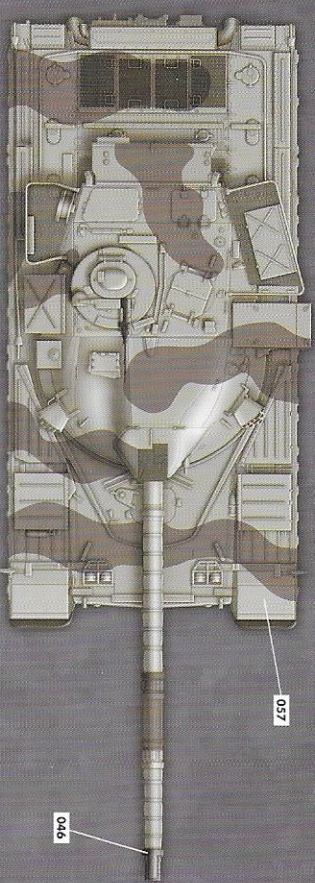

TAKOM Chiefain MK.5/P Ref: 2027

Iranian MK.5/P Recaptured from Iraqi Army by Iranian Revolutionary Guards Corps.

Iranian MK.5/P Army Doy Parade, Tehran, 17th April 2001



CHIEFTAIN MK.5/5P



Color info and profiles by

Painting and Marking Guide

Unknown unit: BATUS - 1991

AMIG 033 Rubber & Tires

AMIG 004 Crystal Glass

AMIG 041 Dark Red

AMIG 045 Gun Metal

AMIG 095 Crystal Smoke

AMIG 096 Prismatic Green

AMIG 041 Warm Sand

AMIG 206 FS 34075 (FS 641)

AMIG 084 NATO Green

AMIG 041 Yellow

AMIG 041 Yellow

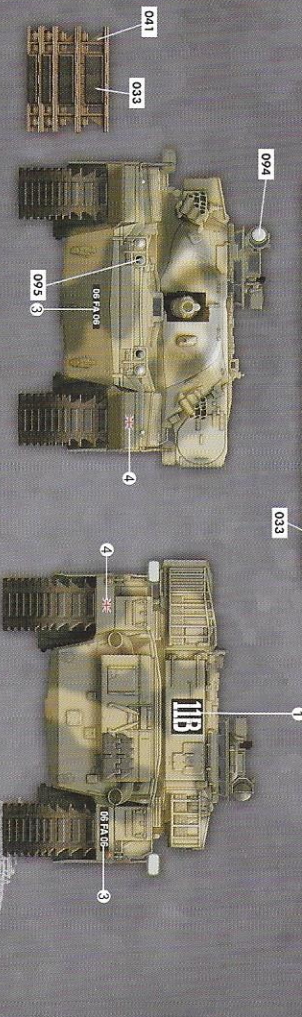
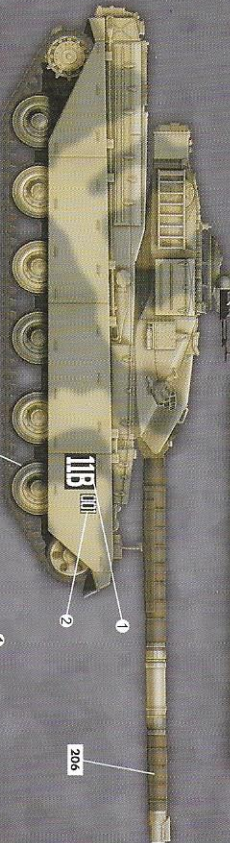
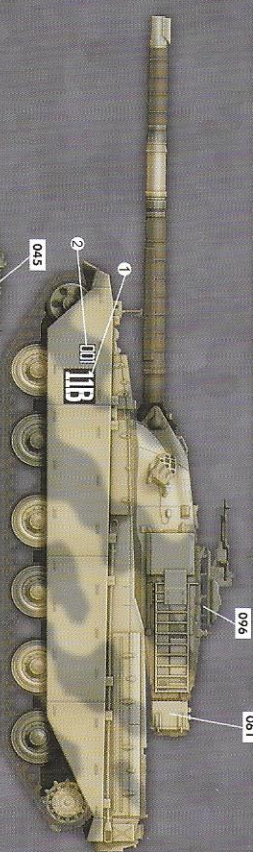
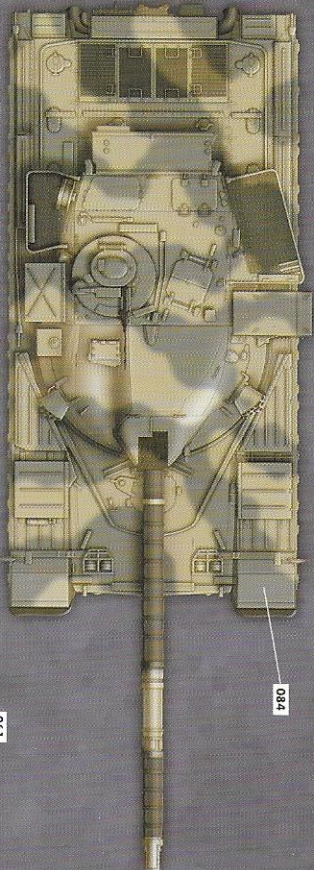

Painting and Marking Guide

Iranian MK.5/P: Battle of Sholomche (preceding the liberation of Khorramshahr) 242nd Battalion, 4th Brigade, 21st Infantry Division, Operation "Bath-e-Ahoozaddas" May 1983

AMIG 033 Rubber & Tires

AMIG 004 Crystal Glass

AMIG 041 Dark Red

AMIG 045 Gun Metal

AMIG 095 Crystal Smoke

AMIG 096 Prismatic Green

AMIG 057 Yellow Grey

AMIG 046 Wolf Black

AMIG 206 FS 34075 (FS 641)

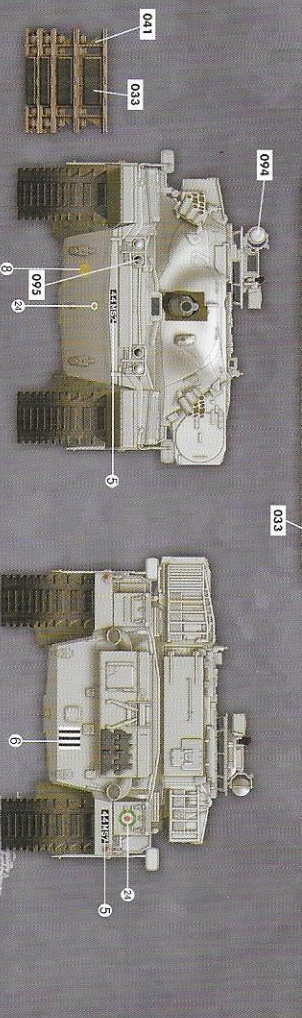
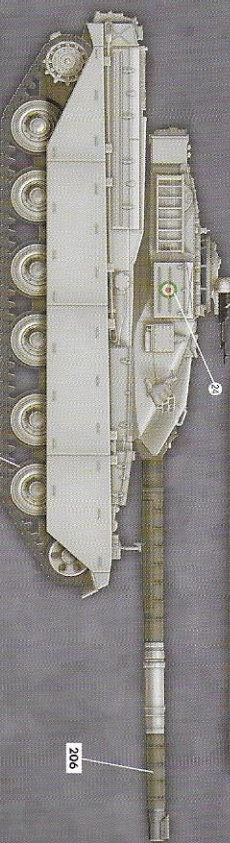
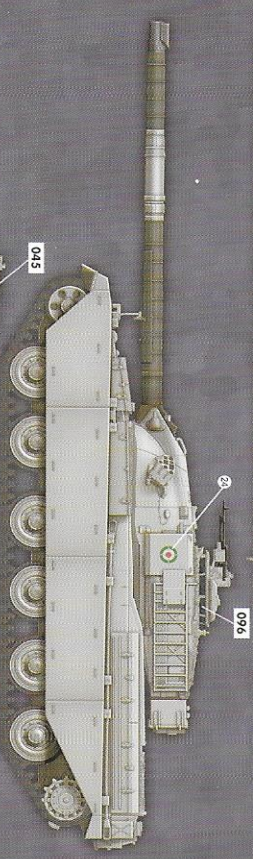
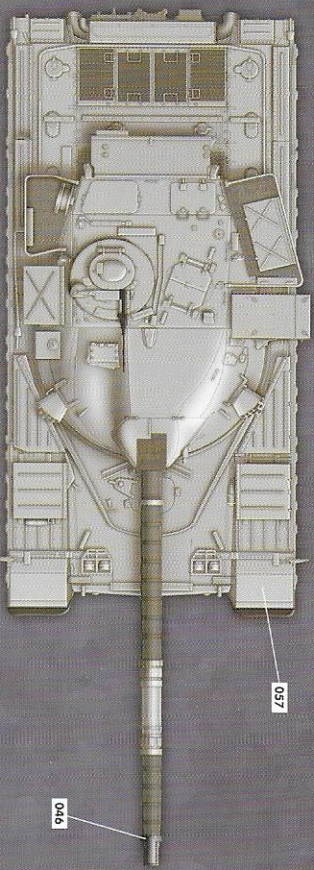

CHIEFTAIN MK.5/5P



Color info and profiles by