

FRENCH LIGHT TANK

# AMX-13/105

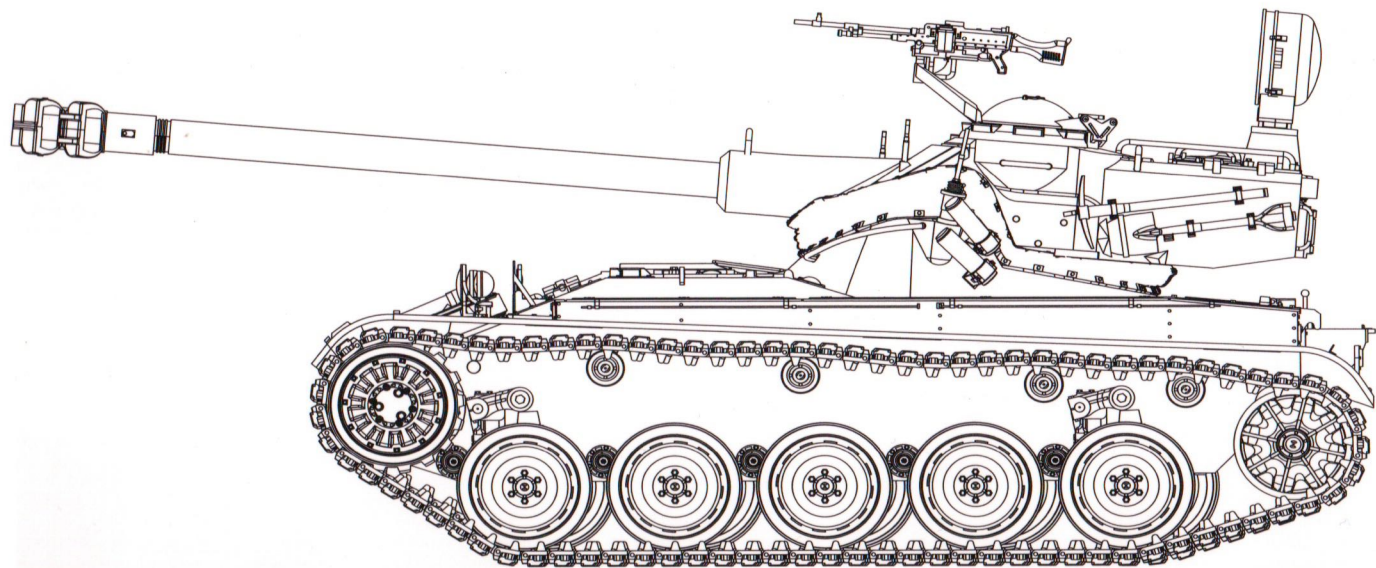

Adopted by the French Army to replace their aging fleet of U.S. supplied light tanks, the AMX-13 was designed in 1950's by Atelier de Construction D'Issy-les-Mouneux, and produced by Atelier de Construction Roanne until 1987 with some 7,700 examples having been produced. The most striking feature of the AMX-13 tank is its oscillating GIAT turret; rather than the gun pivoting on trunnions within the turret, a 'sub-turret' (and the gun) elevates within the rotating turret. This design eliminates the normally bulky mantle/gun shield on conventional designs, and allows a lower overall height. Developed specifically for export, the FL-12 turret was fitted with a 105mm main gun which fires the same rounds as the AMX-30, but with a lighter charge. With a combat weight of 14.8 tons and a crew of 3, the AMX-13/105 is powered by either a Baudouin 6F 11 SRY turbo-charged 6-cylinder water-cooled engine, or a Detroit Diesel 6V-53T turbo-charged 6-cylinder water-cooled, diesel engine with a synchromesh automatic transmission providing 5 forward and 1 reverse speeds reaching a road speed of 60km/h. The tank is constructed of welded steel armor plates ranging from 20mm to 40mm thick, with the engine located in front for added protection.

# READ BEFORE ASSEMBLY

## CAUTION

- Read carefully and fully understand the instructions before commencing assembly. A supervising adult should also read the instructions if a child assembles the model.
- When assembling this kit, tools including knives used. Extra care should be taken to avoid personal injury.
- Keep out of reach of small children. Children must not be allowed to suck any part, or pull vinyl bag over their heads.



Optional



Remove



Be Careful



Drill



Instant Glue  
for Metal



Fill Holes

## PAINTS REQUIRED

Color info and profiles by Mig Jimenez

A.MIG 033	Rubber & Tires	A.MIG 034	RustTracks	A.MIG 045	Gun Metal
A.MIG 083	Crystal Red	A.MIG 094	Crystal Glass	A.MIG 081	US Olive Drab
A.MIG 026	German Sand Brown	A.MIG 050	Matt Withe	A.MIG 051	Light Green KHV-553M

## APPLYING DECALS

1. Clean the model surface with a wet cloth.
2. Cut out each decal design from sheet, and dip it in tepid water for 15~20 sec.
3. Hold the backing sheet edge and slide decal onto the model.
4. Move decal into position by wetting decal with finger.
5. Press decal gently down with a soft cloth until excess water and air bubbles are gone.

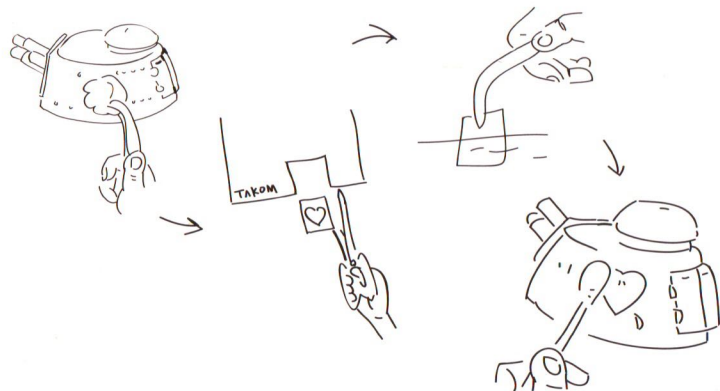

## REMOVING PE

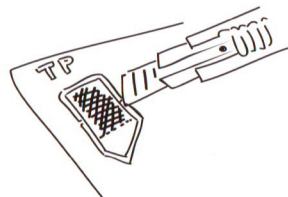

Be careful not to hurt when removing PE parts.

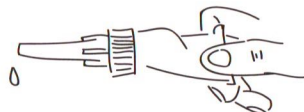

Secure using instant glue (not included).

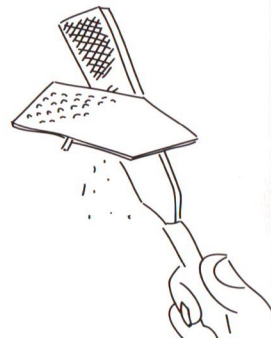

Finish using file.

# PARTS

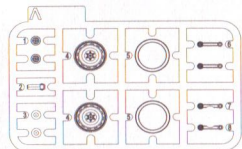

X5

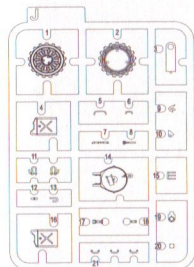

X2

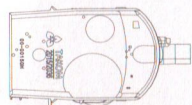
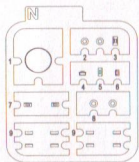

Turret

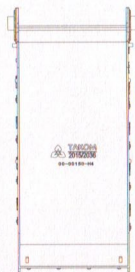
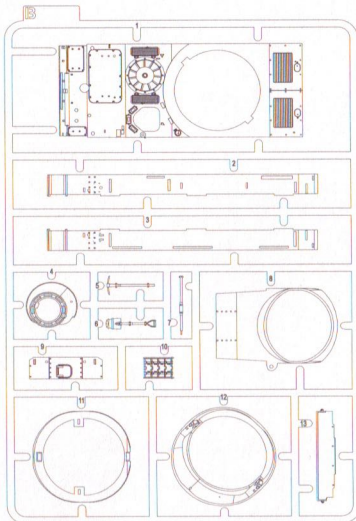

Lower Hull

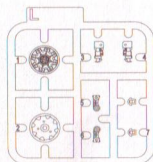

X2

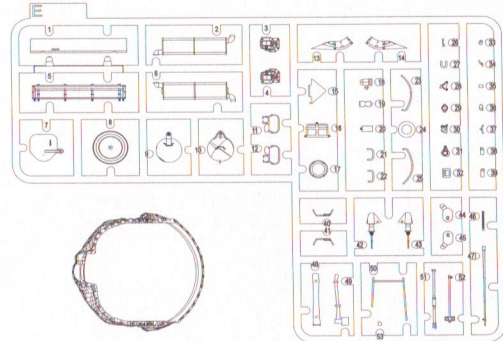
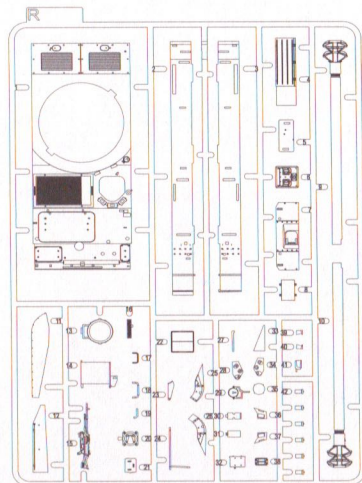
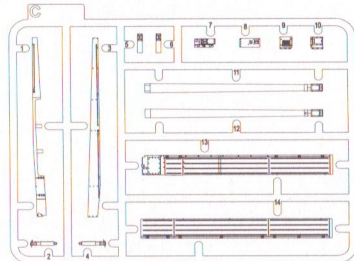

Dust Cover



X10

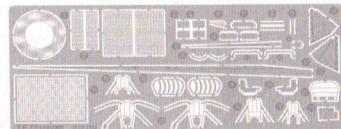

TP



Decal

1

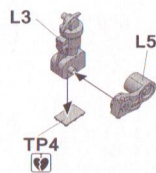
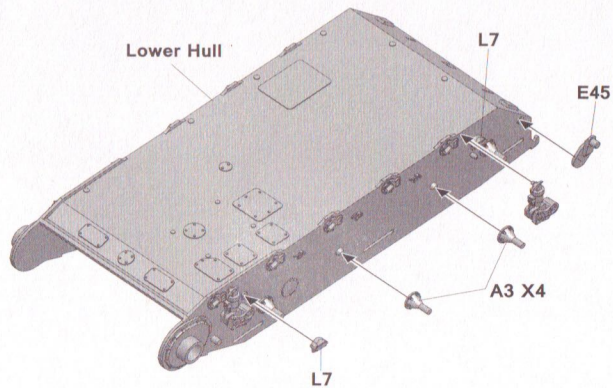

**Make 2**

2

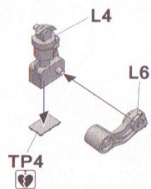

**Make 2**

3

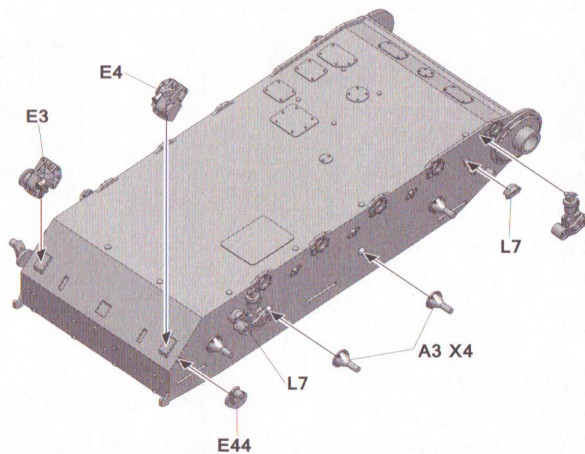
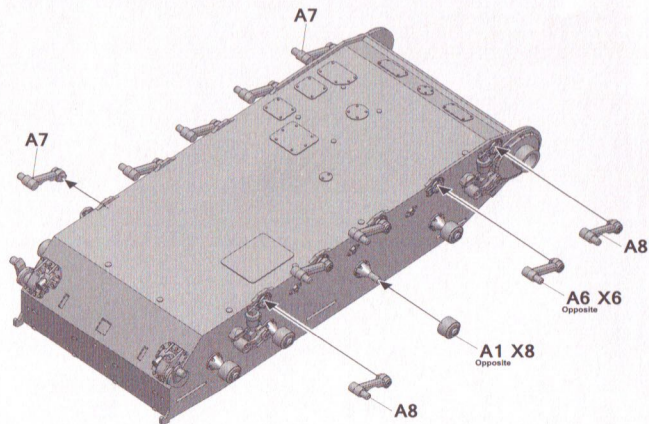

3

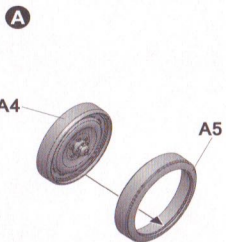
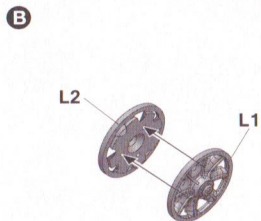
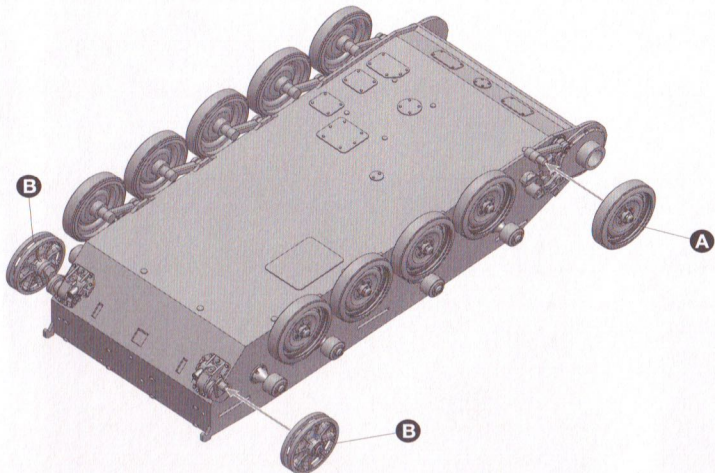
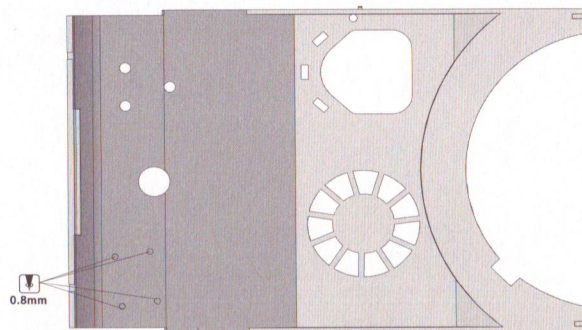
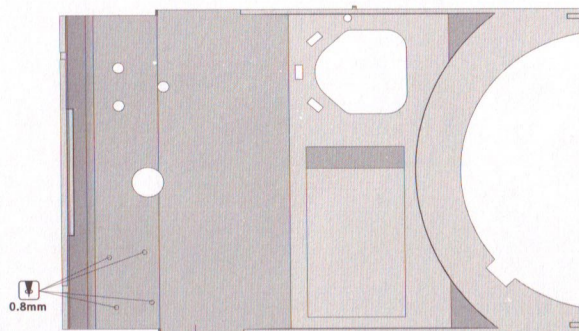
**4****Make 10****Make 2****5****6-1****B1****6-2****R1**

7-1

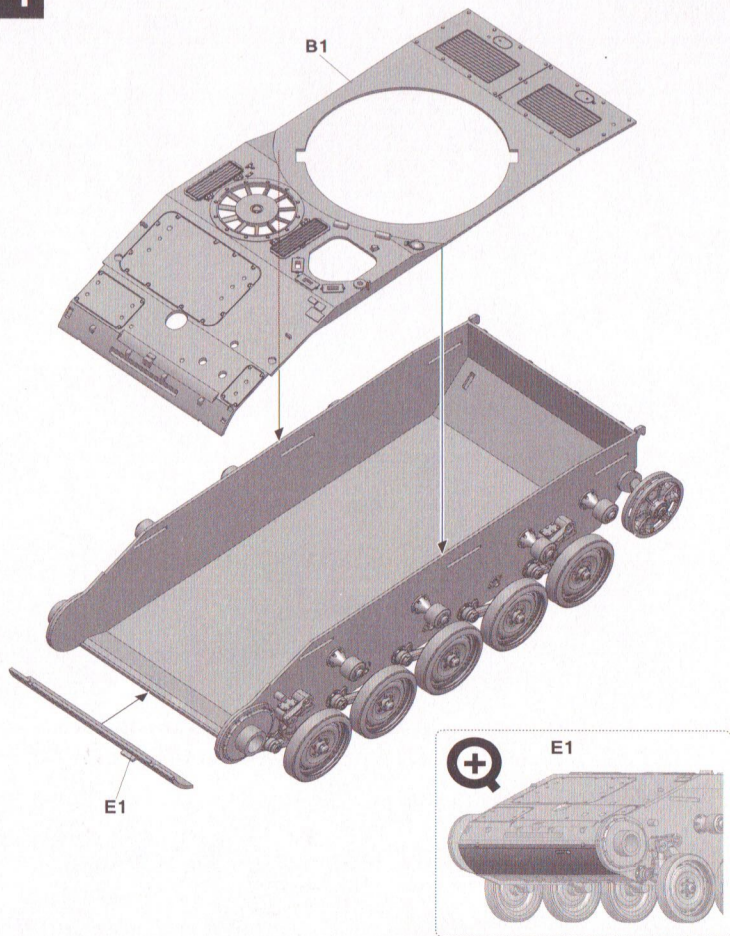

7-2

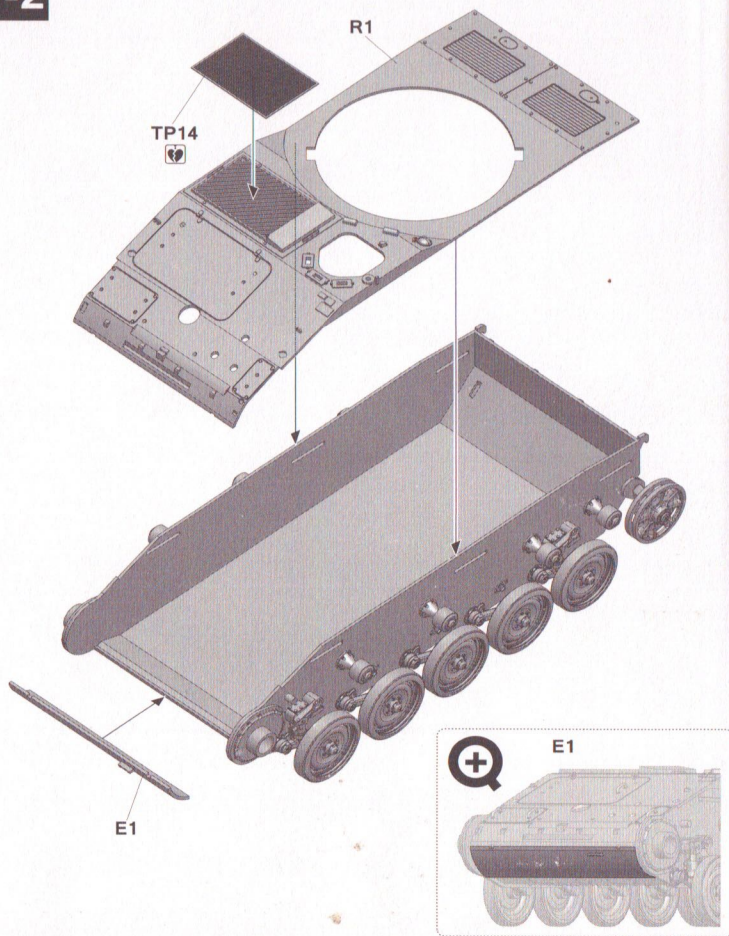

# 8-1

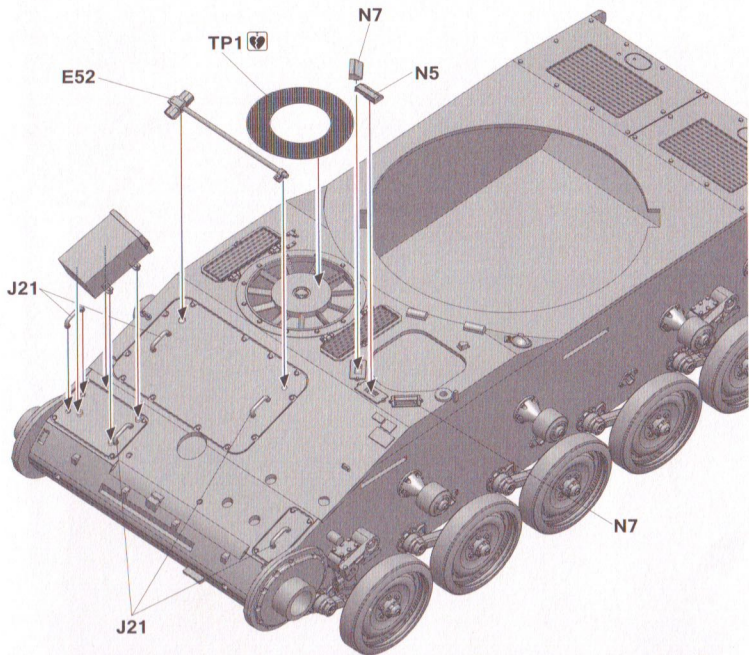
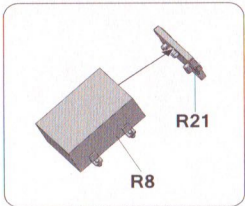

# 8-2

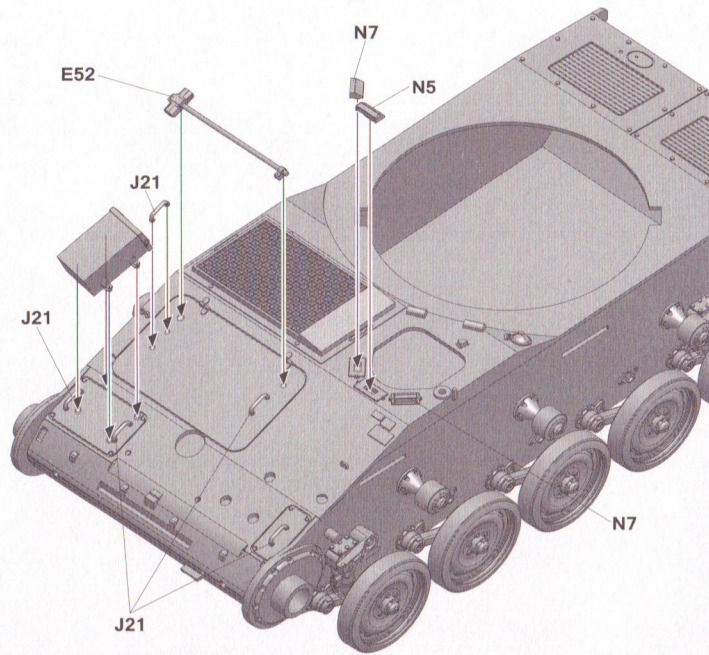
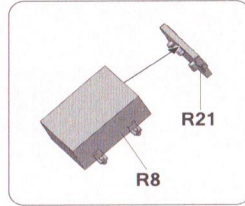

# 9-1

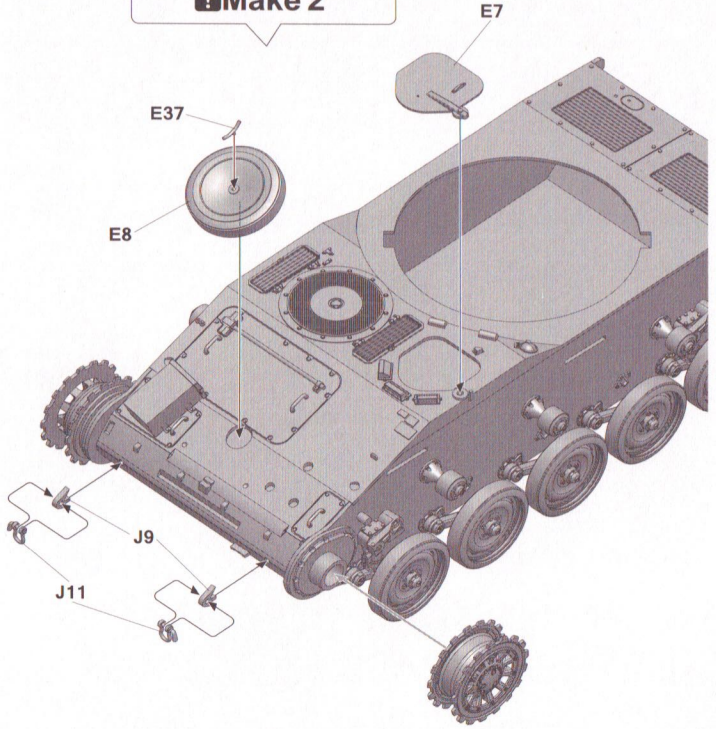
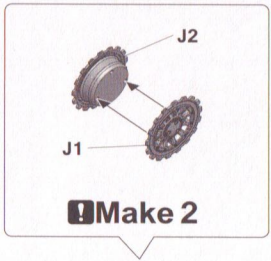

# 9-2

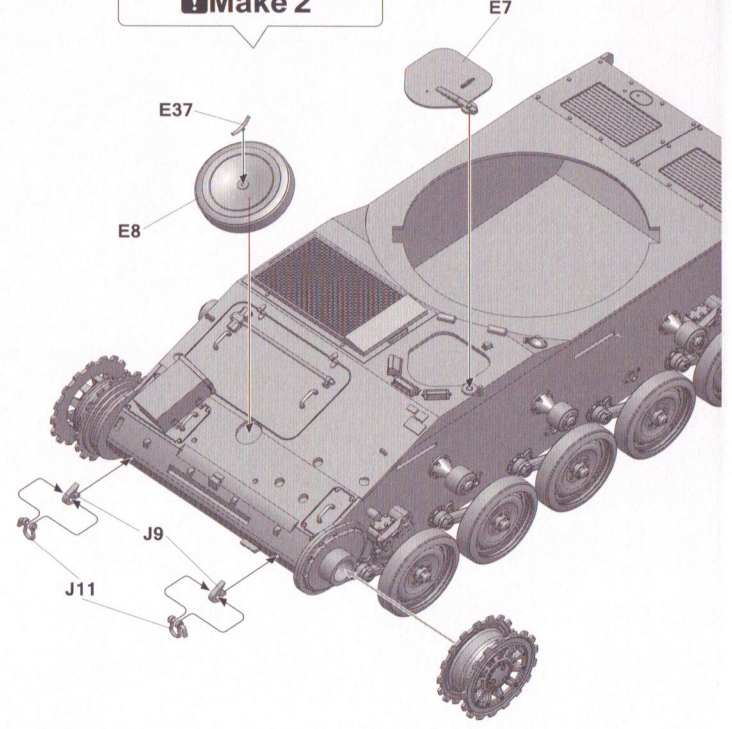
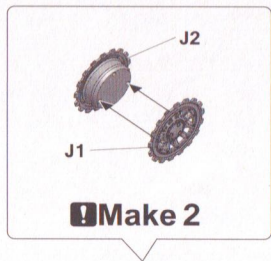



# 10-1

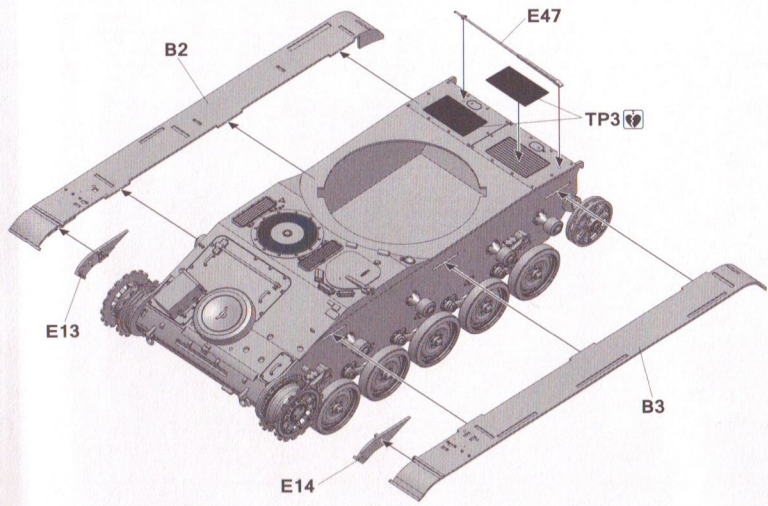
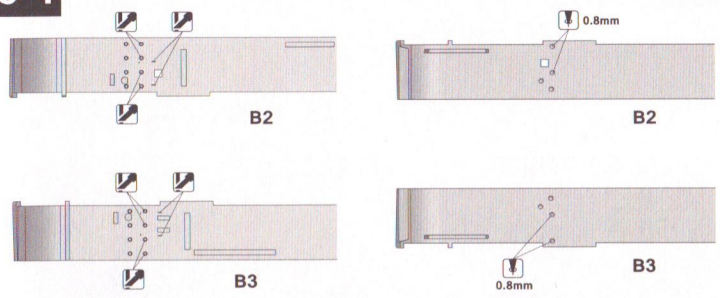

# 10-2

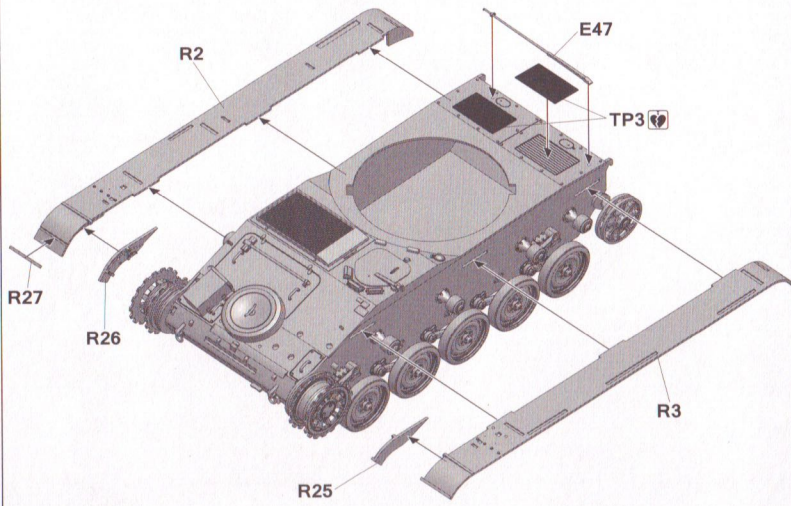
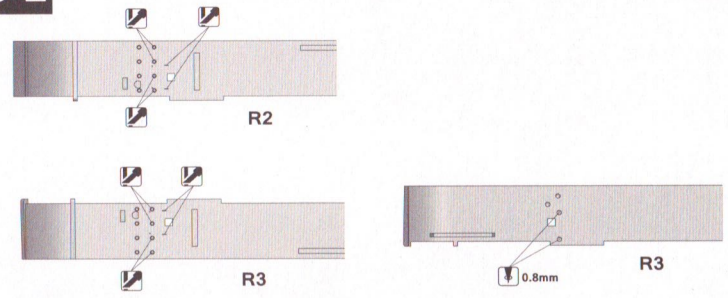

11-1

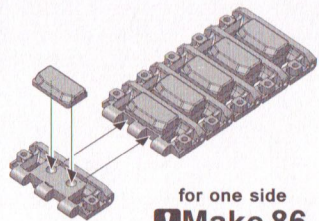

for one side  
**Make 86**

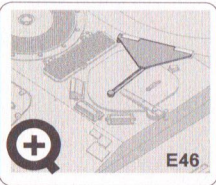
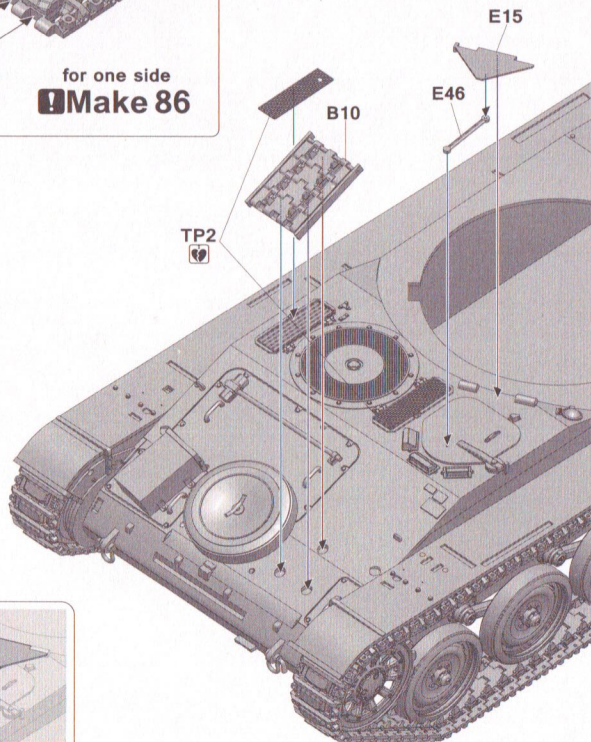

E46

11-2

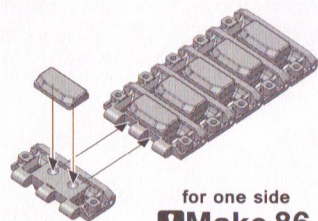

for one side  
**Make 86**

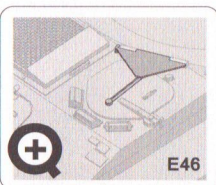
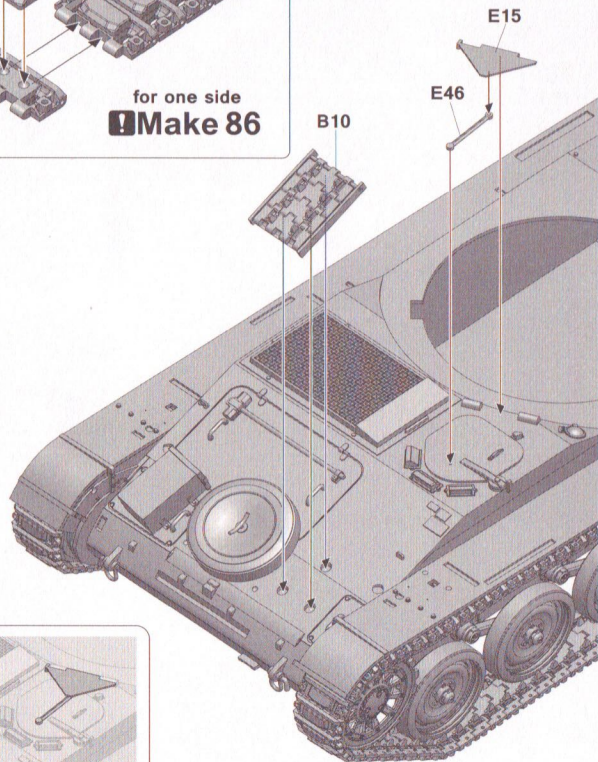

E46

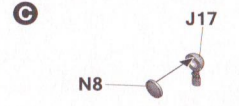
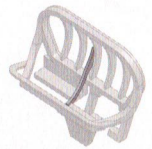
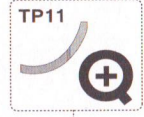
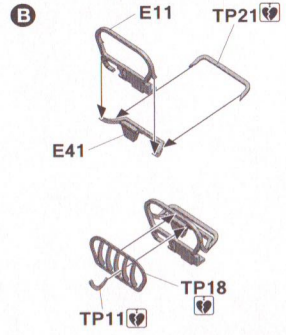
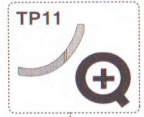
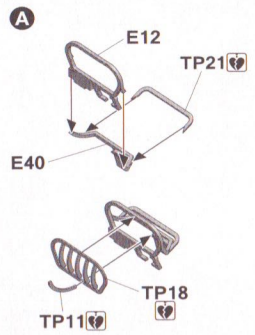

**Make 2**

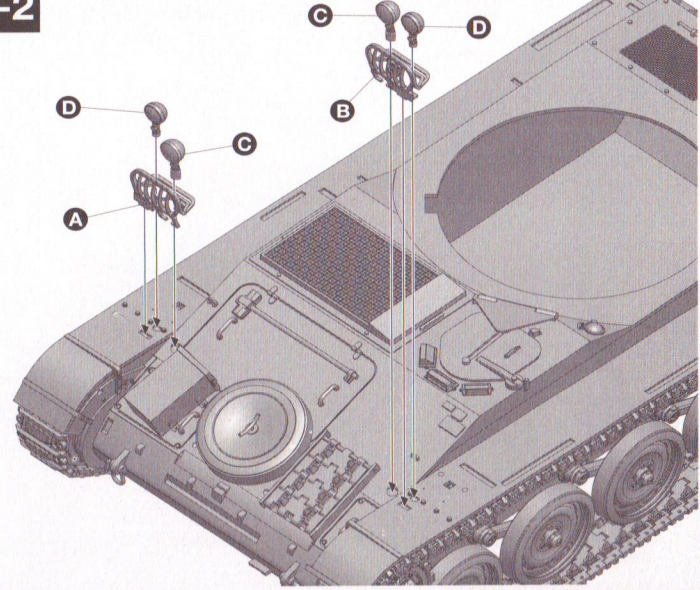
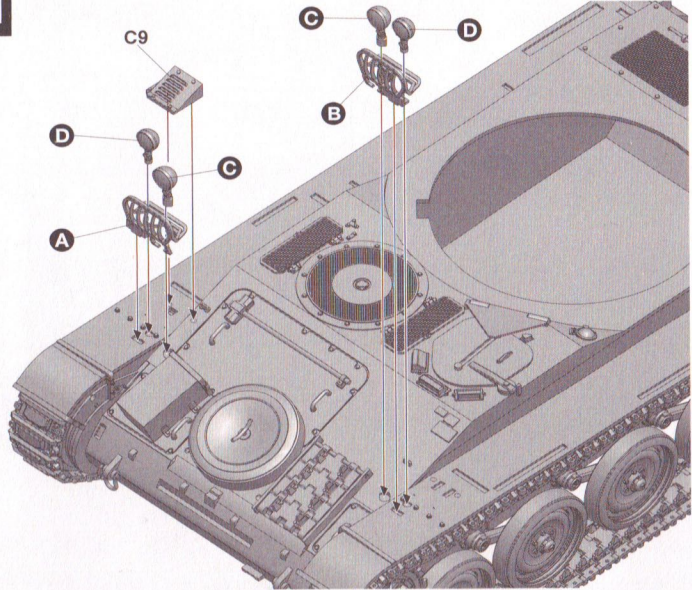
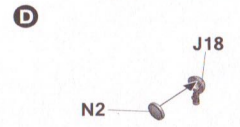

14

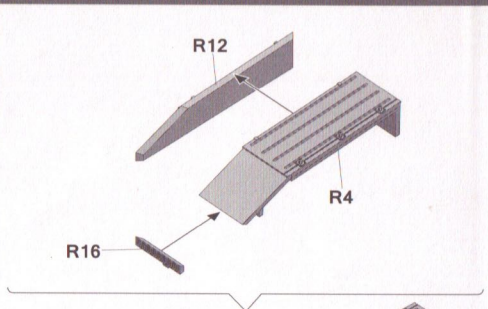
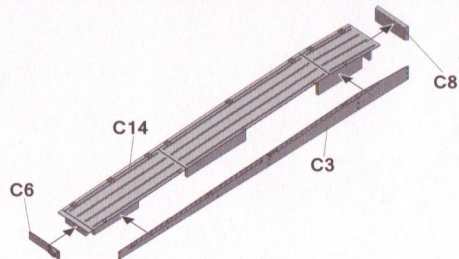
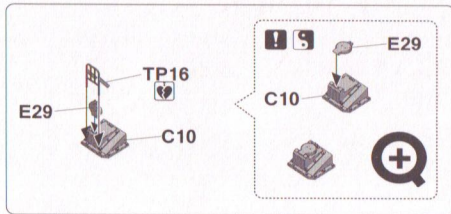

15-1

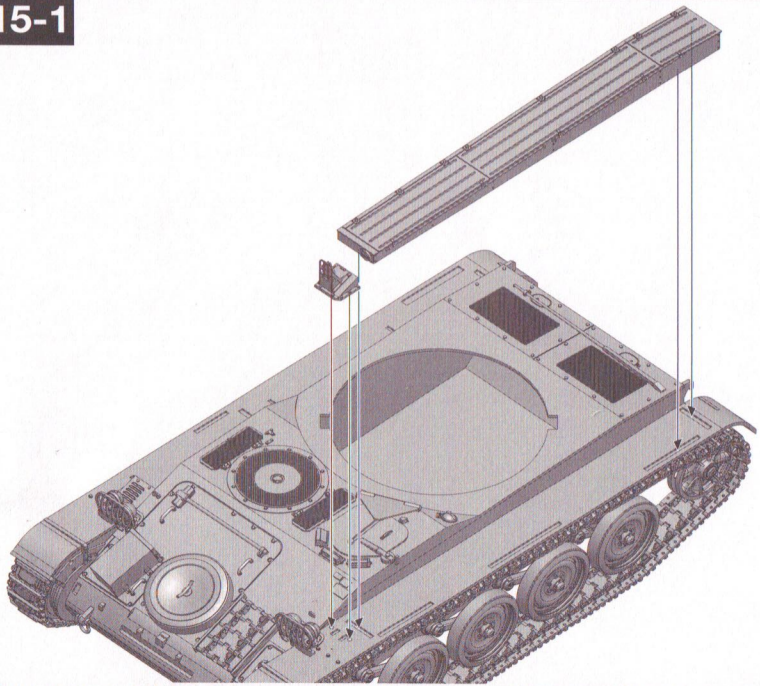

15-2

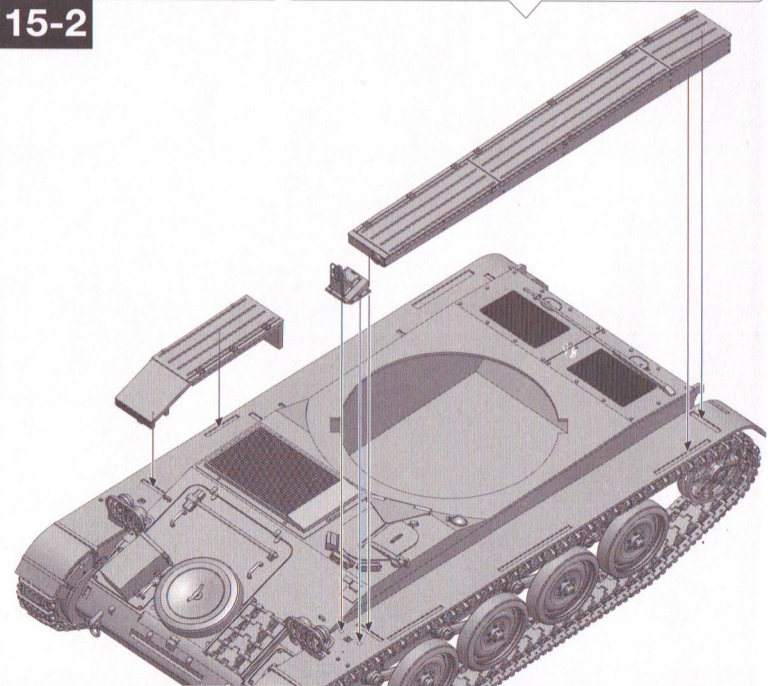

# 16-1

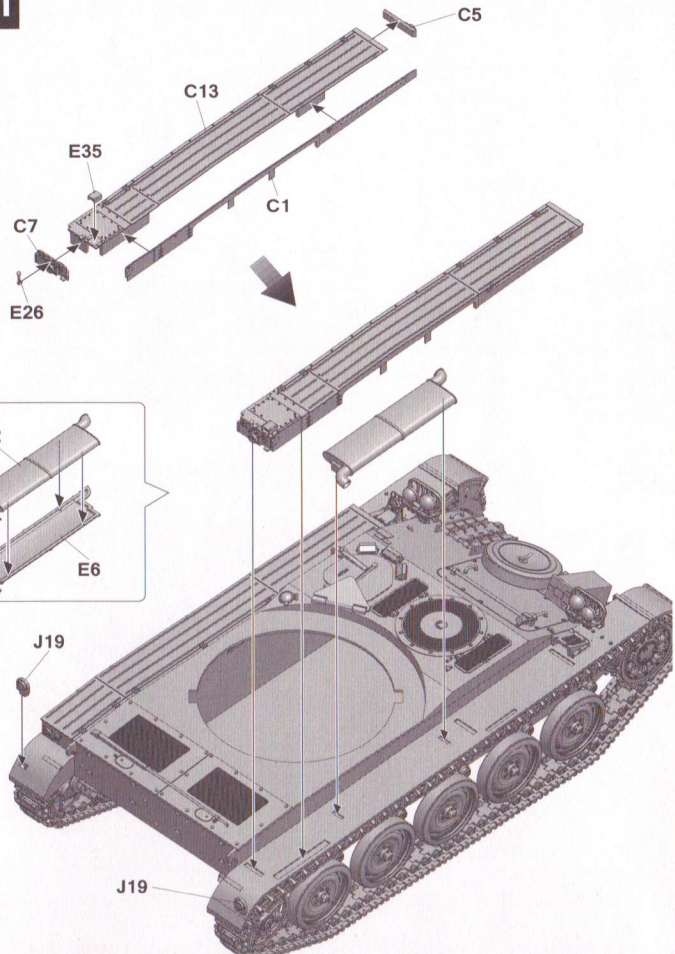

# 16-2

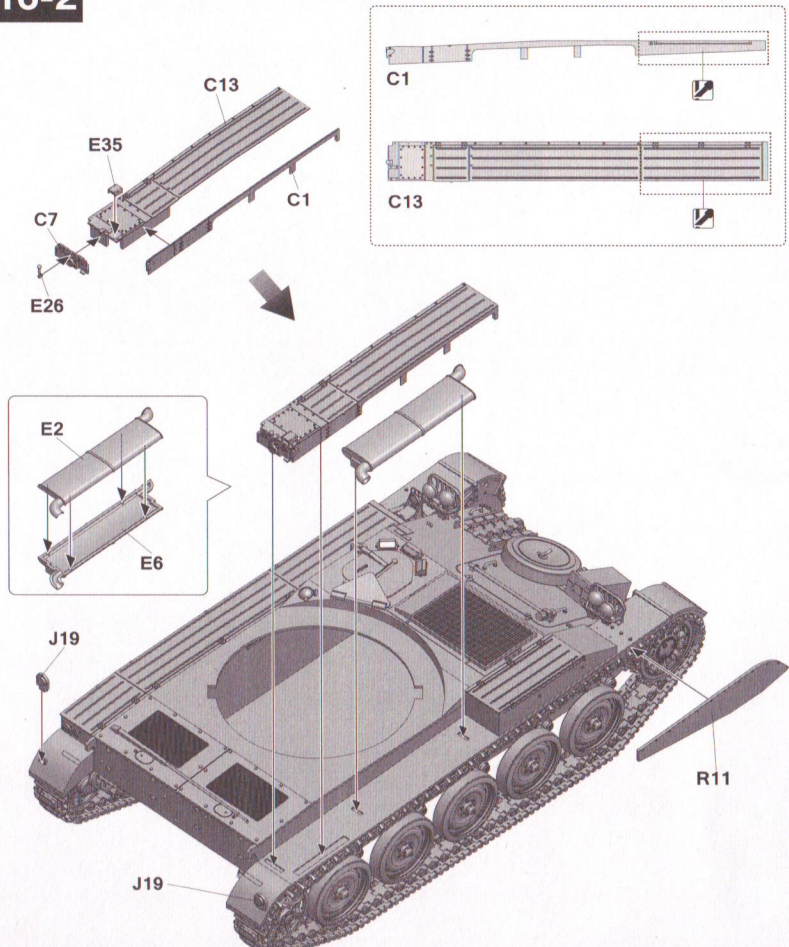

17-1

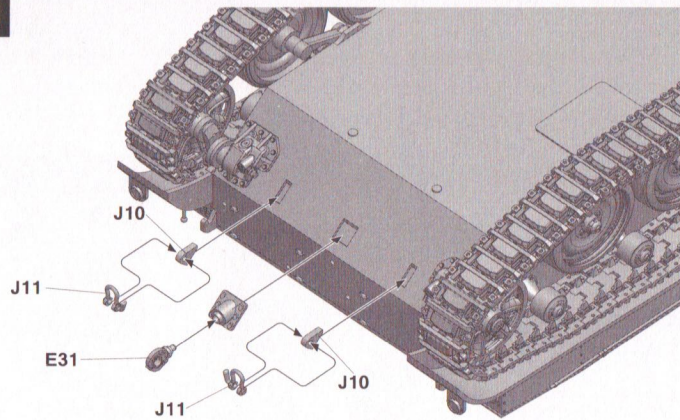

17-2

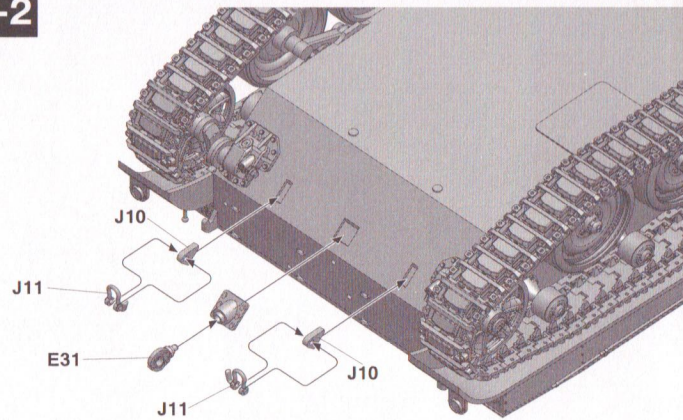

18-1

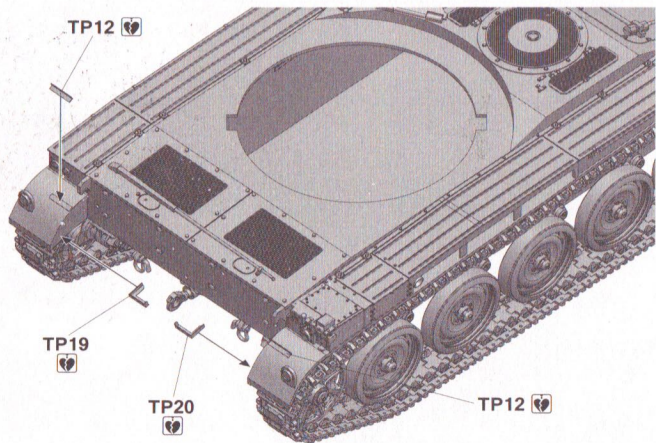

18-2

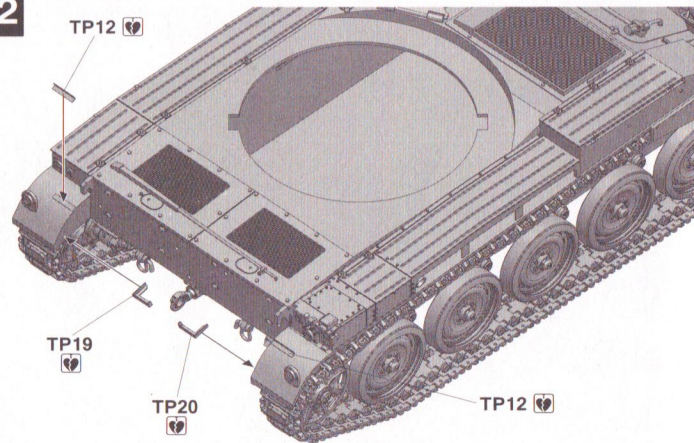

19-1

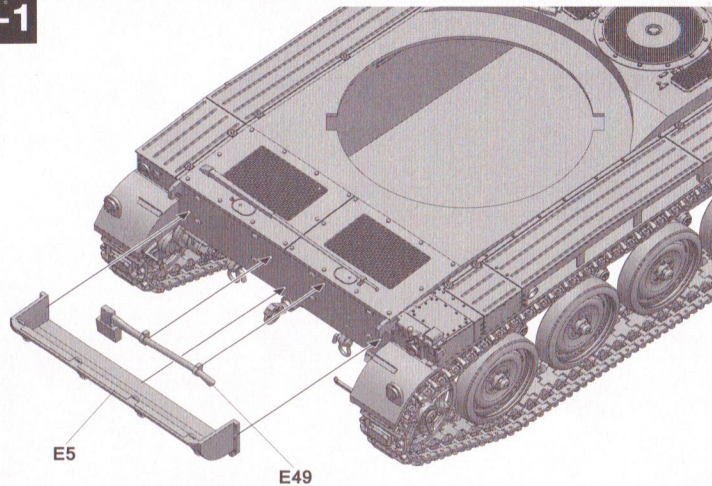

19-2

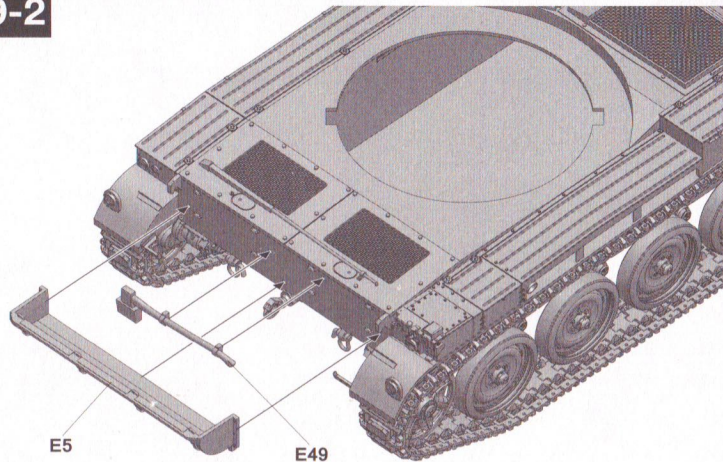

20-1

Turret

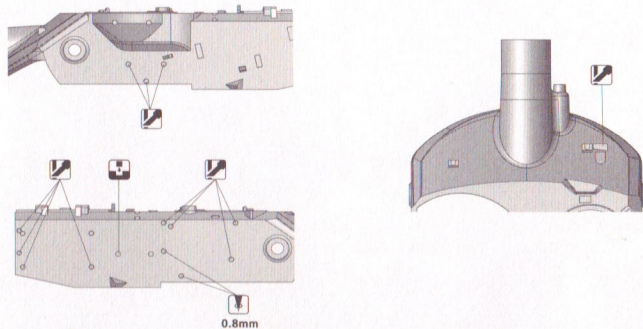

20-2

Turret

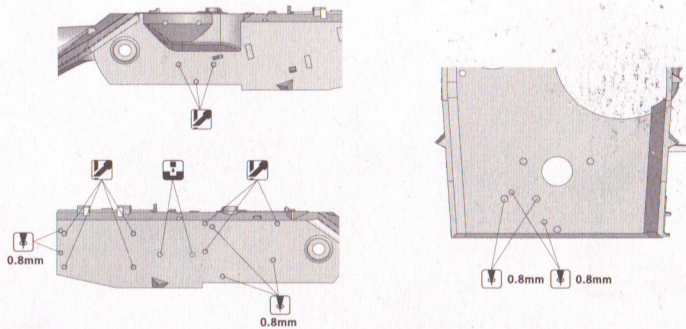

21-1

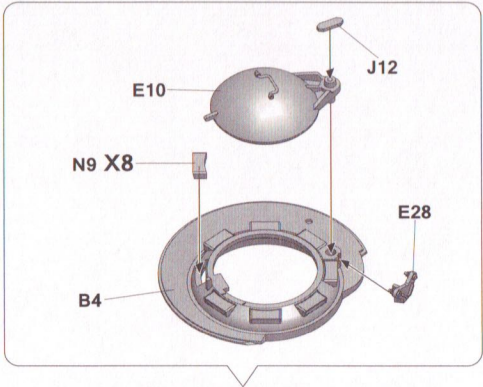

21-2

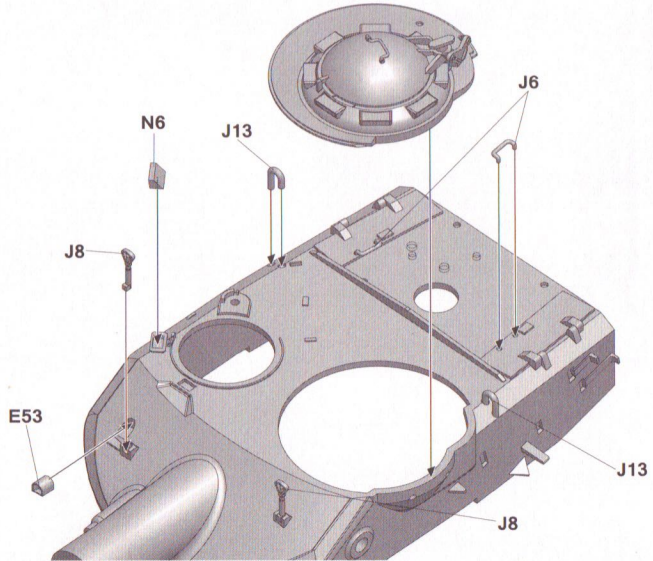
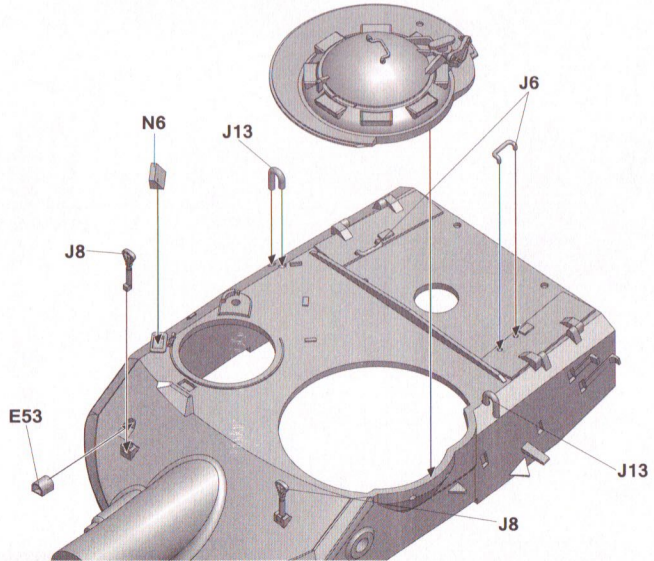
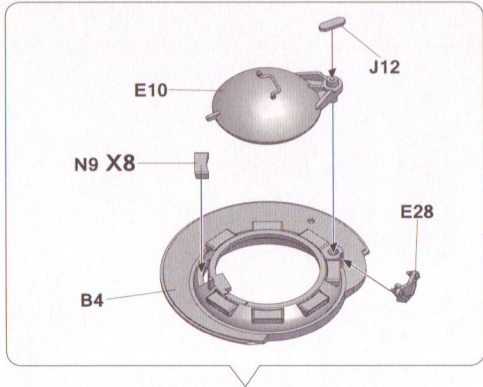



22-1

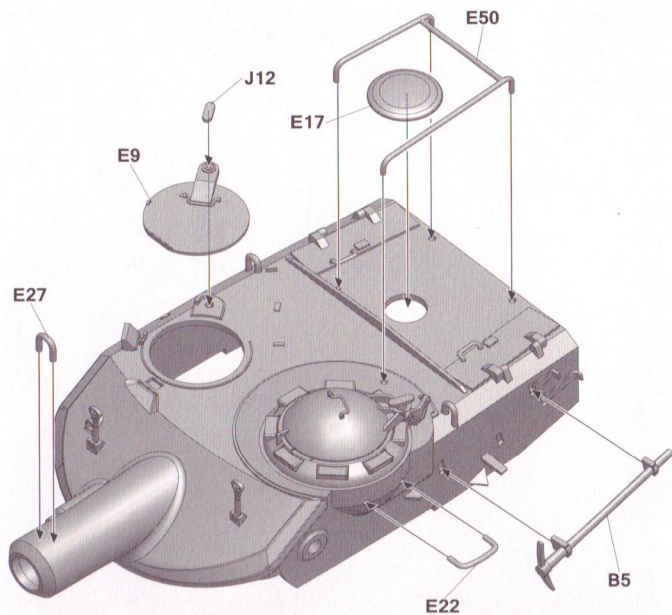
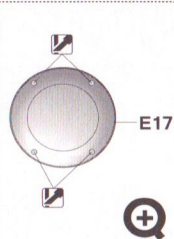
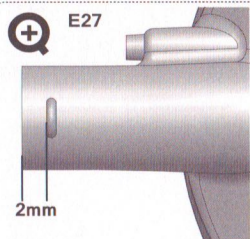
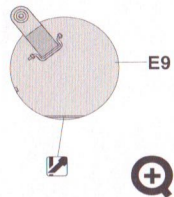

22-2

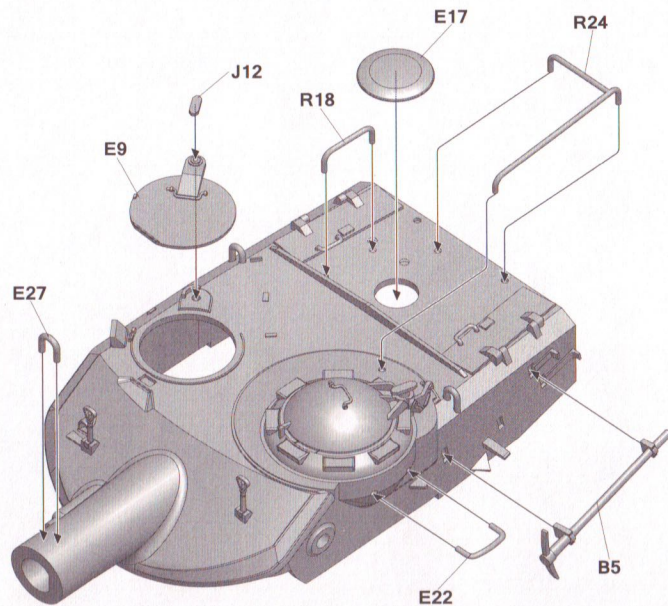
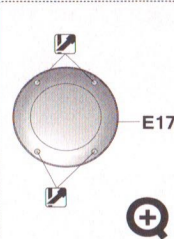
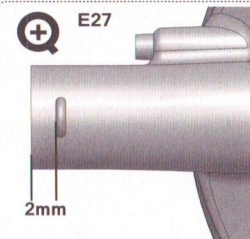
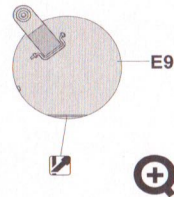

22-1

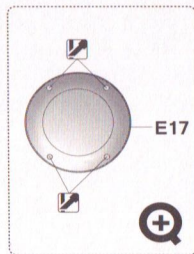
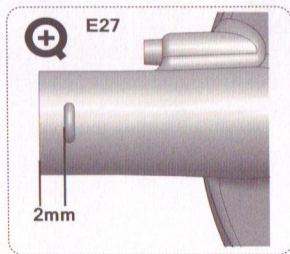
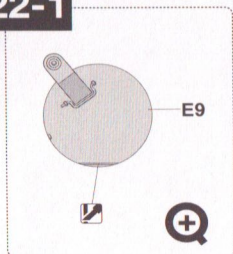

22-2

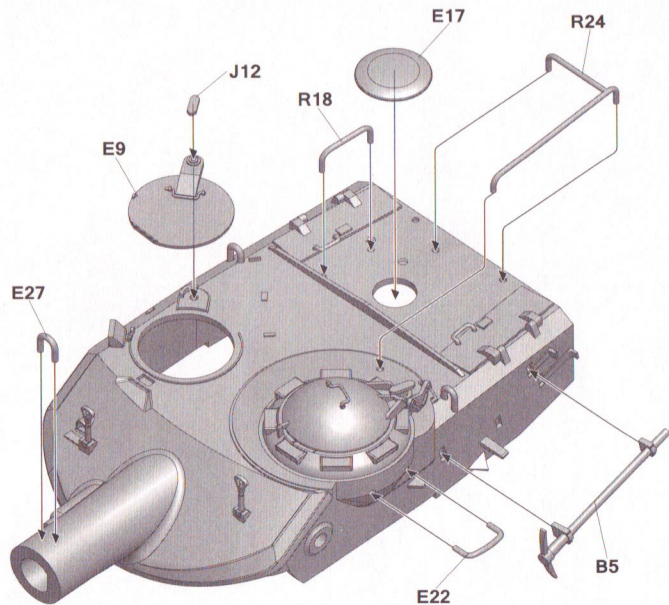
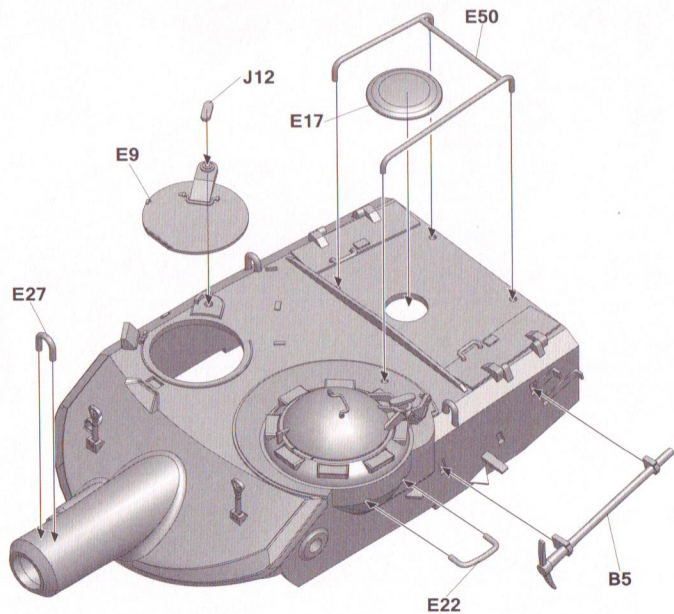
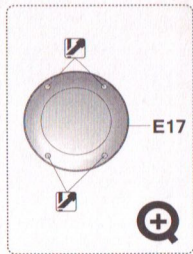
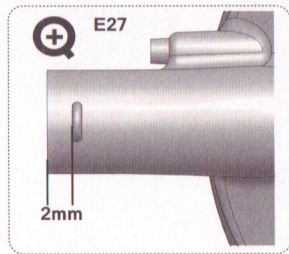
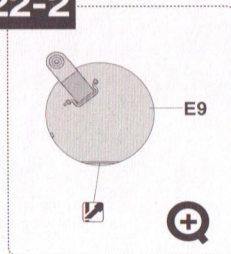

26-1

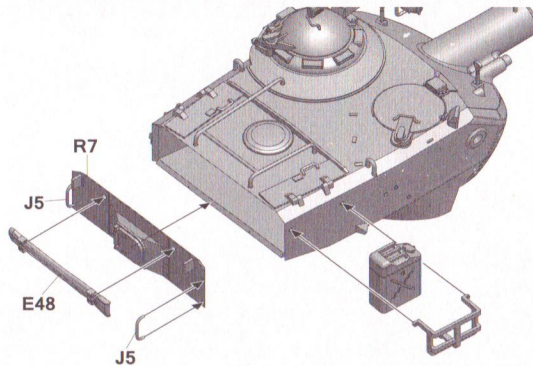
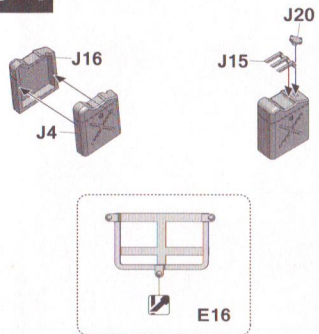

26-2

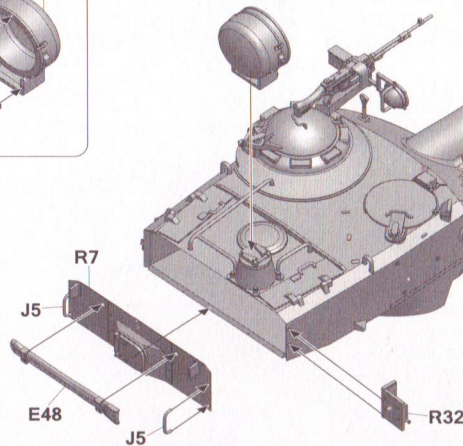
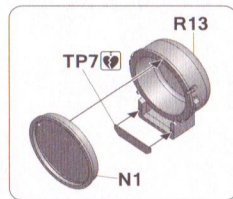
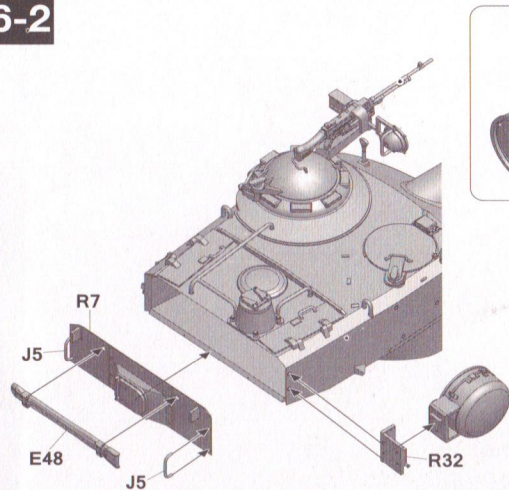

27

with Dust Cover

Dust Cover  
A.MIG 071 Khaki

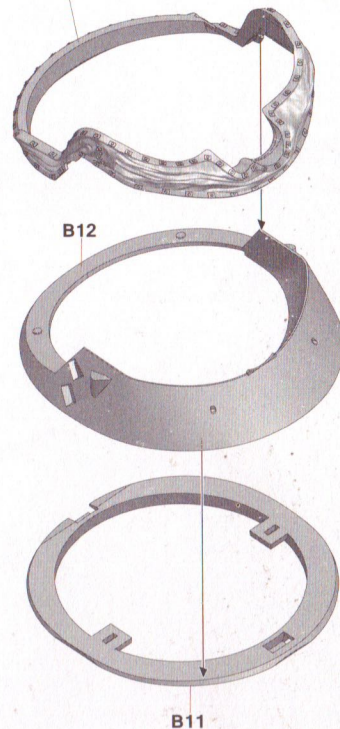

28-1

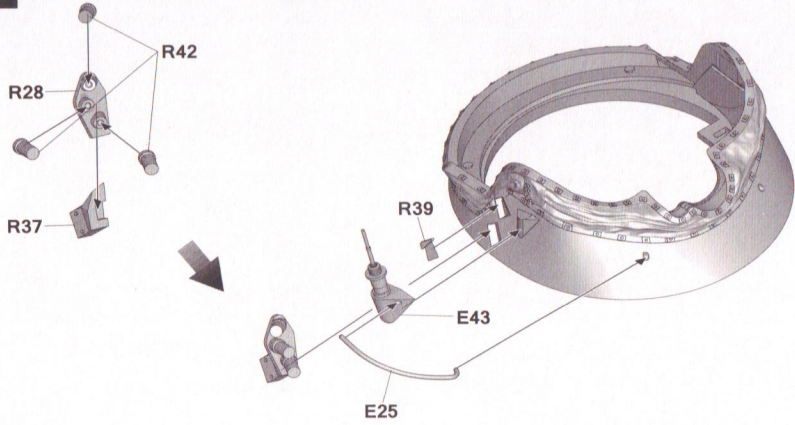

28-2

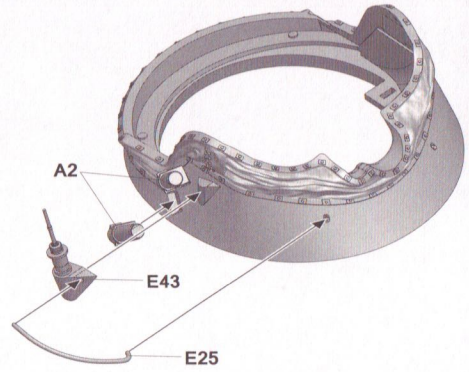

29-1

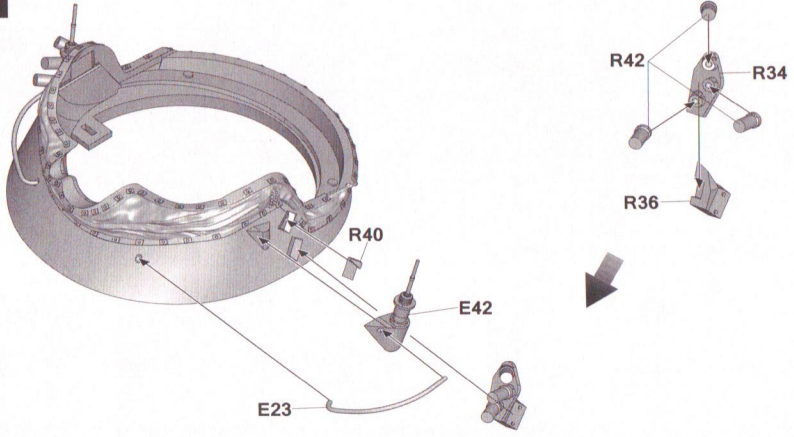

29-2

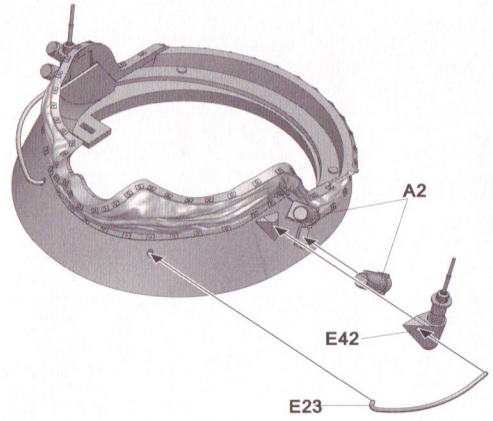

30-1

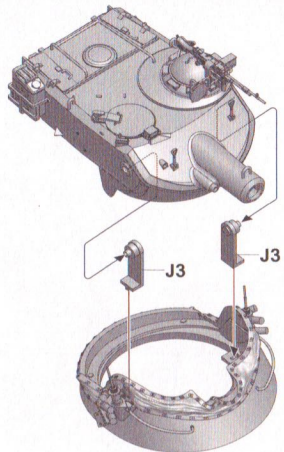

30-2

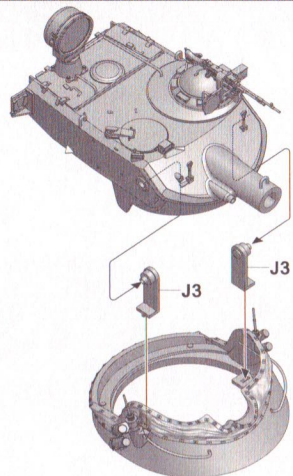

31

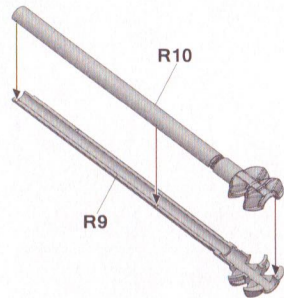

32-1

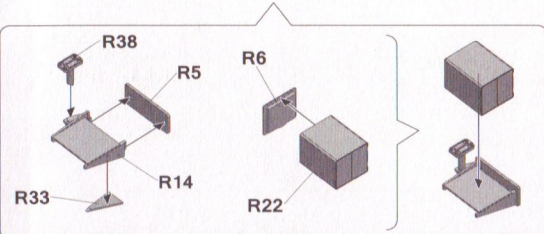
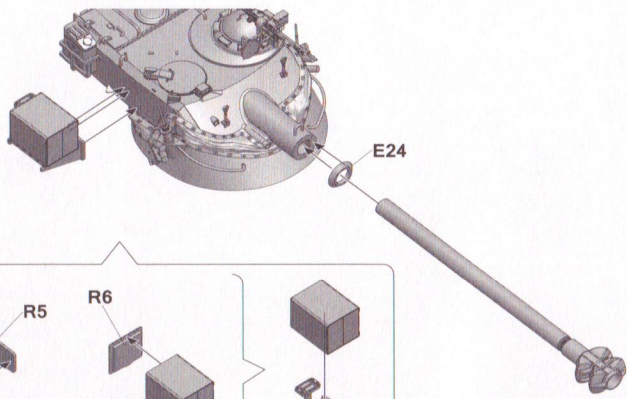

32-2

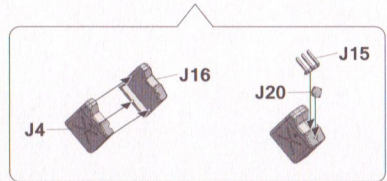
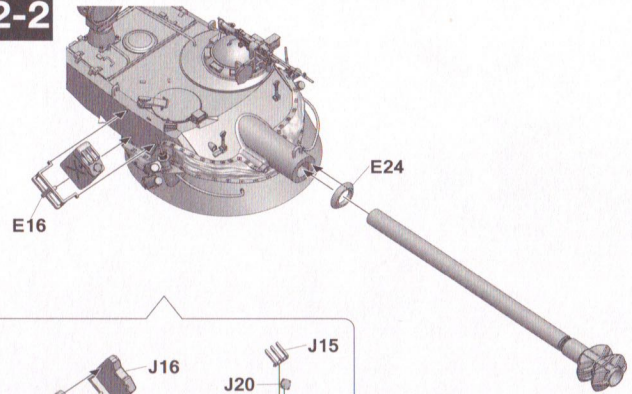

# 33-1

**A**

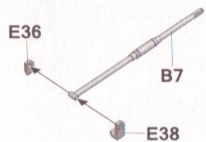

**B**

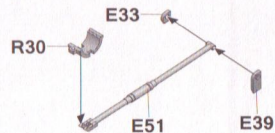

# 33-2

**A**

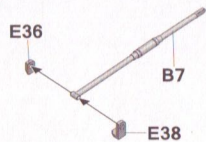

**B**

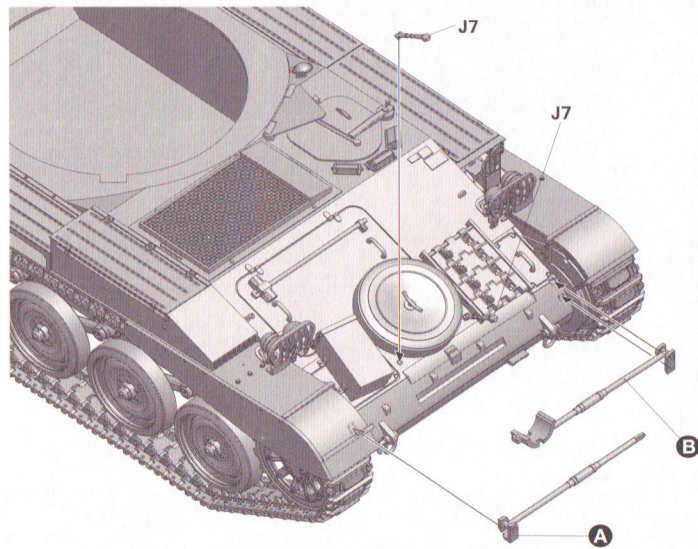
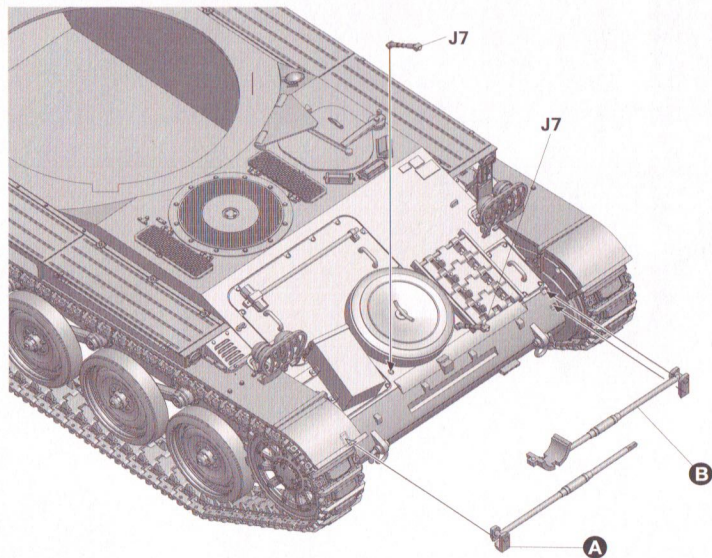
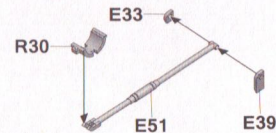

# 34-1

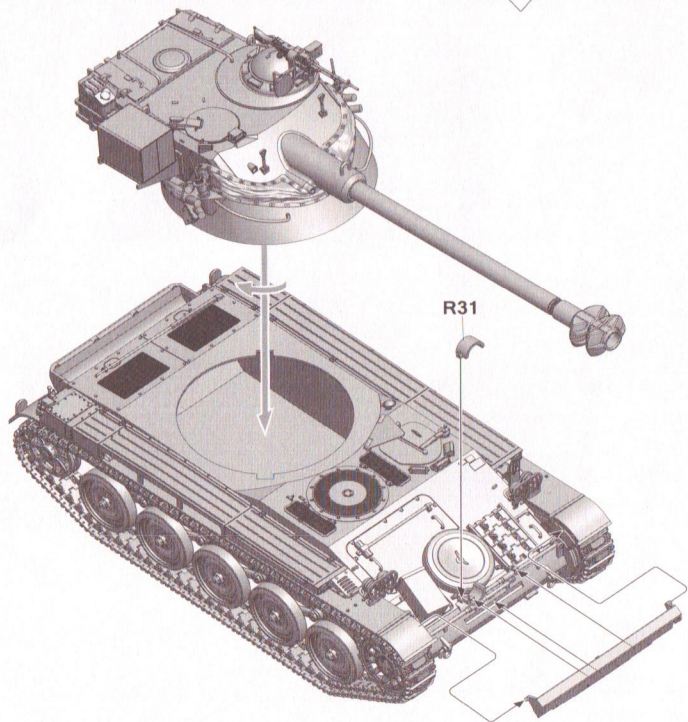
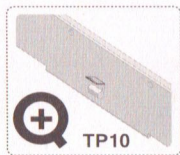
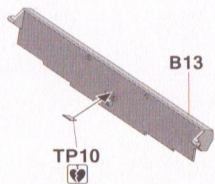

# 34-2

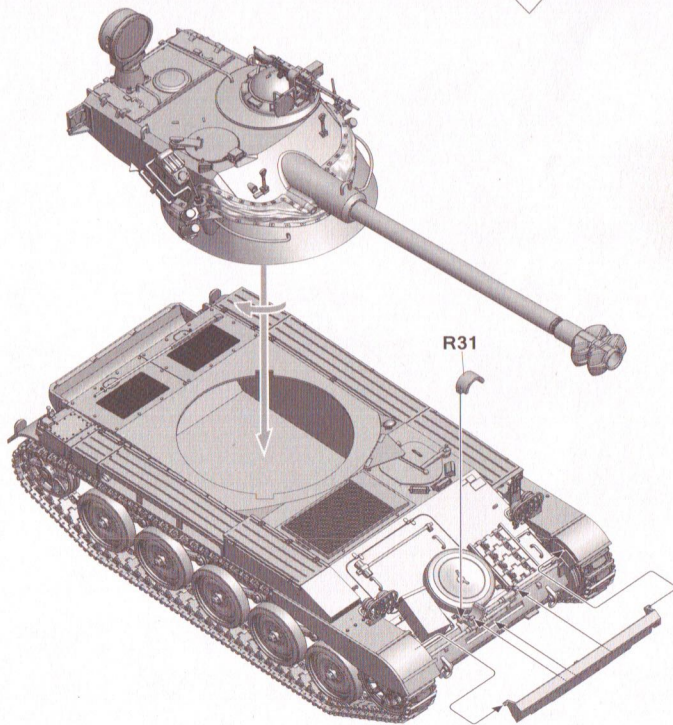
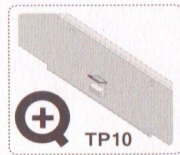
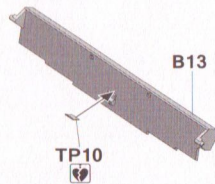

35-1

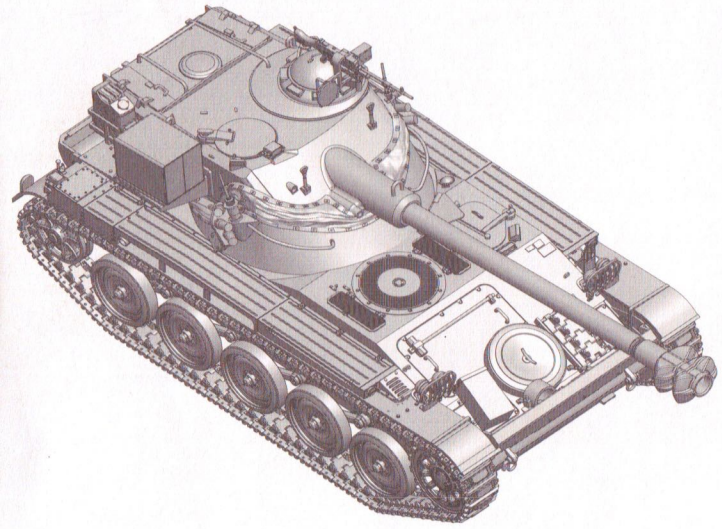

35-2

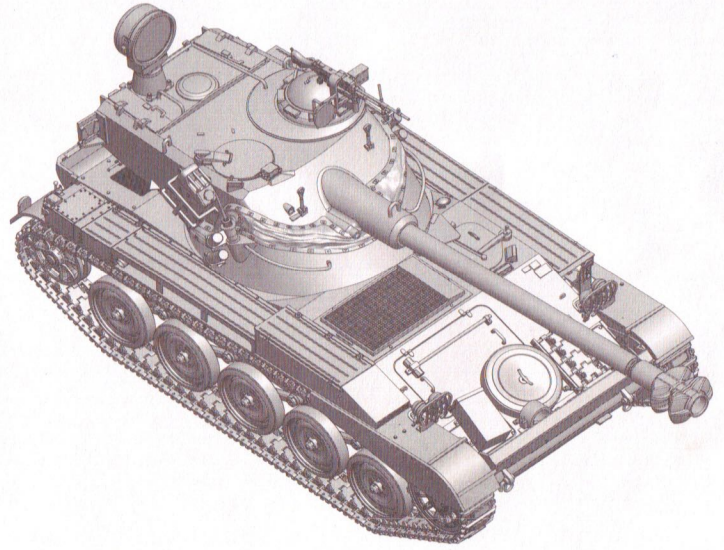



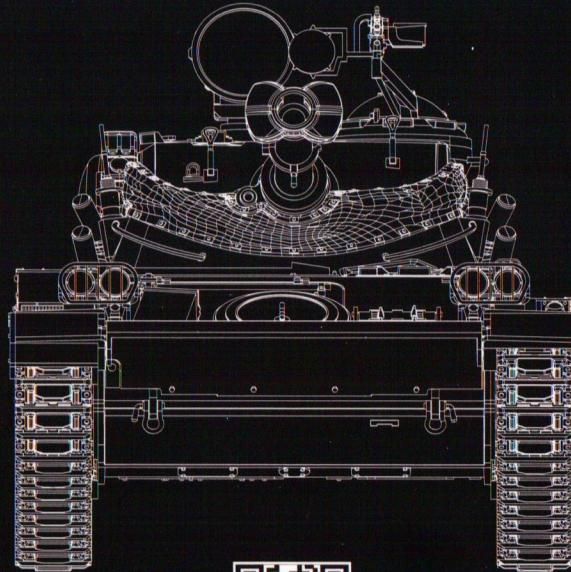

You can find TAKOM on Facebook.com

## Painting and Marking Guide

**A.MIG 033** Rubber & Tires

**A.MIG 034** Rust Tracks

**A.MIG 045** Gun Metal

**A.MIG 093** Crystal Red

**A.MIG 094** Crystal Glass

**A.MIG 081** Olive Drab

AMX-13 Early, 5th Cavalry Regiment,  
Argentinean Army.

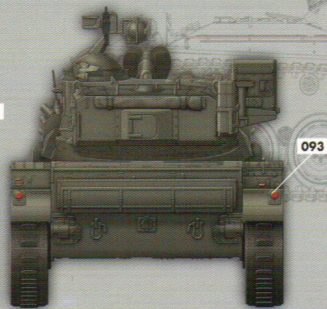
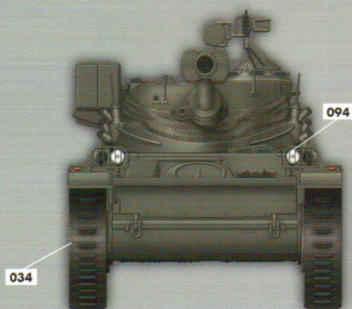
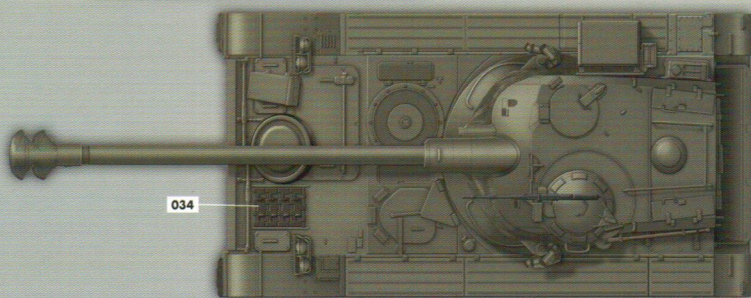
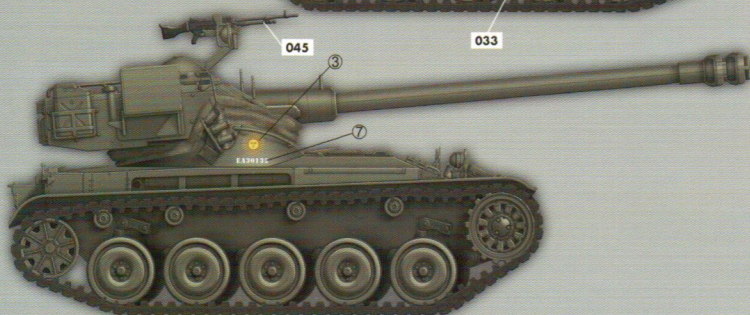
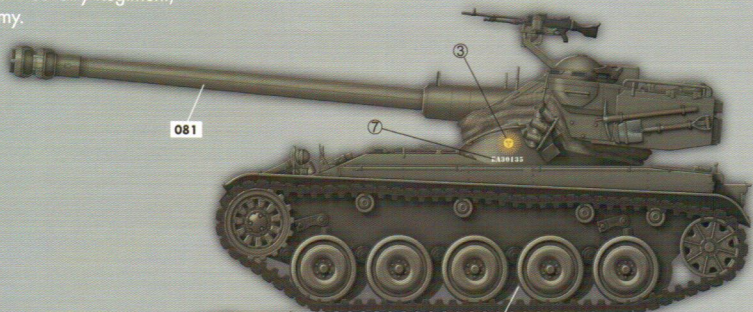

# AMX-13/105

## Painting and Marking Guide

A.MIG 033

Rubber &amp; Tires

A.MIG 034

Rust Tracks

A.MIG 045

Gun Metal

A.MIG 093

Crystal Red

A.MIG 094

Crystal Glass

A.MIG 026

German Sand  
Brown

A.MIG 050

Matt White

A.MIG 051

Light Green

AMX-13 Repotenciado, 15° Regimiento de  
Infanteria de Montaña, Ejército Argentino.

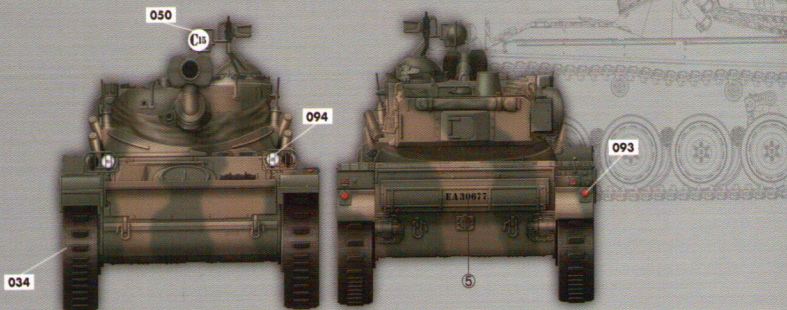
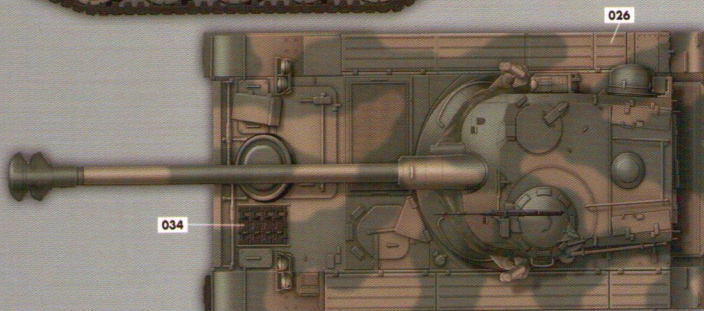
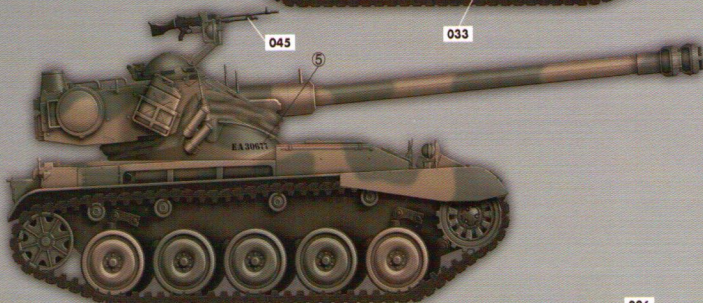
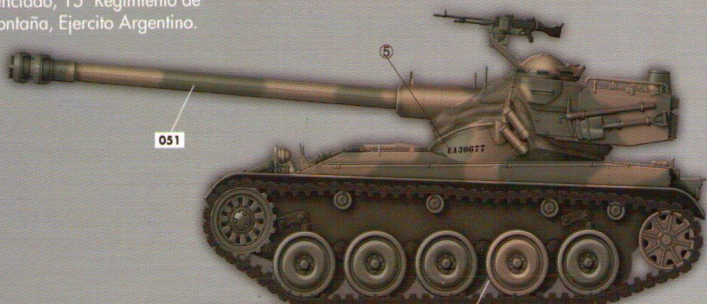

# AMX-13/105



## Painting and Marking Guide

A.MIG 033

Rubber & Tires

A.MIG 034

Rust Tracks

A.MIG 045

Gun Metal

A.MIG 093

Crystal Red

A.MIG 094

Crystal Glass

A.MIG 081

Olive Drab

Dutch Army.

*MA 71315 MA 71000*

*MA 71072*

*MC 70934*

*71209 MA*

